

Operating Manual

FTC300

Gas analysis using thermal conductivity measurement



About this manual

Thank you for using the Messkonzept FTC300. It has been designed and manufactured using highest quality standards to give you trouble free and accurate measurements.

© Copyright Messkonzept GmbH 2020.

This document is protected by copyright. Neither the whole nor any part of it or the information contained in it may be adapted or reproduced in any form except with the prior written approval of Messkonzept.

All information of technical nature and particulars of the product and its use (including the information in this manual) are given by Messkonzept in good faith. However, it is acknowledged that there may be errors or omissions in this manual. Images and drawings may not be in scale. For the latest revisions to this manual contact Messkonzept or visit www.messkonzept.de
Messkonzept welcomes comments and suggestions relating to the product and this manual.

Please Note! The design of this instrument is subject to continuous development and improvement. Consequently, this instrument may incorporate minor changes in detail from information contained in this manual.

Important! In correspondence concerning this instrument, please specify the type number and serial number as given on the type label on the right side of the instrument.

All correspondence should be addressed to:

Messkonzept GmbH
Niedwiesenstr. 33
60431 Frankfurt
Germany

Tel: +49(0)69 53056444
Fax: +49(0) 69 53056445
email: info@messkonzept.de
[http: www.messkonzept.de](http://www.messkonzept.de)

This manual applies to: FTC300
Date of Release: October 9, 2020

Quick Installation Guide

For quick installation of the FTC300 we recommend to read the following chapters of this manual:

- Chapter 1 "Operator Safety": Important warnings, safety instructions and intended use.
- Chapter 3 "Assembly of the Instrument": Mounting, pneumatic and electric connection. Also see Chapter 12 "Appendix: Dimensional Drawing"
- Chapter 6 "Calibration": Recommended calibration intervals, the calibration process and recommended test of functionality after bringing into service.

Contents

1	Operator Safety	5
1.1	Notes on Safety Conventions and Icons	5
1.2	Warning Notices	6
1.3	Safety Instructions	7
1.4	Intended Use	8
2	Principle of Measurement	9
2.1	Determining Concentrations via Thermal Conductivity	9
3	Assembly of the Instrument	13
3.1	FTC300 Detector Unit	13
3.2	Installation of the FTC300	13
3.3	Gas Ports	14
3.4	Electrical Connectors and Ground	15
3.4.1	Requirements for Electrical Connectors	17
3.4.2	Ground	17
3.4.3	Data exchange via serial interface (RS-232)	17
4	The Front Panel	19
4.1	Display	19
4.2	LED Indicators	19
4.3	Keys	20
5	Switching on the device	21
5.1	Warm up Screen	21
5.2	Operation Screen	22
5.3	Top Level Main Menu	22
6	Calibration	23
6.1	General Information on Calibration	23
6.1.1	Calibration gas purities and flooding time	23
6.2	Set Offset Gas Concentration	24
6.3	Set Gain Gas Concentration	24
6.4	Offset Calibration	25
6.5	Gain Calibration	26
6.5.1	Use of Substitute Gases	26
7	Diagnosis	27
7.1	Parameter Menu	27
7.2	Errors	28

8 Setup	29
8.1 The Setup Menu	29
8.2 Instrument Setup	30
8.2.1 Display Unit	30
8.2.2 Measuring Gas Setup	30
8.2.3 Response Time Setup	31
8.2.4 Multi Gas Mode List (only with MGM-option)	32
8.3 Relay Setup	33
8.3.1 Relay 1 Mode	33
8.3.2 Relay 1 Threshold	34
8.3.3 Relay 1 Hysteresis	34
8.3.4 Relay 1 failsafe / Not failsafe	35
8.3.5 Relay 1 active/frozen during calibration	36
8.3.6 Relay 2	37
8.3.7 Common Relay	38
8.4 Analog Output Setup	39
8.4.1 Current Loop modes and adjustment of the measuring range	39
8.4.2 Analog Output 1	41
8.4.3 Analog Output 2	42
8.4.4 Current loop calibration	42
8.5 Expert Setup	43
8.5.1 Parameter	43
8.5.2 Access Modes	44
8.5.3 Reset Functions	44
8.5.4 Test of Relays, Analog Outputs and Connections	45
9 Appendix: System Errors	47
10 Appendix: Specifications	50
10.1 Specification of Thermal Conductivity Measurement	50
10.2 Electrical Specifications	51
10.3 Permissible Conditions of the sample to be measured	52
10.4 Environmental conditions	52
10.5 Dimensions	52
11 Appendix: Menu Tree of the FTC300	53
12 Appendix: Dimensional Drawing	57

Chapter 1

Operator Safety

This chapter provides information and warnings which must be followed to ensure safe operation and retain the instrument in safe condition. Read this section carefully before beginning to install and use the instrument.

1.1 Notes on Safety Conventions and Icons



This icon draws attention to application errors or actions that can lead to safety risks including the injury to persons or malfunctions, possibly even destruction of the device.

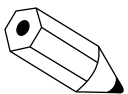

This icon indicates an additional function or hint.

1.2 Warning Notices



- The manufacturer does not assume liability for inappropriate handling of the device. Malfunctions caused by inappropriate handling may lead to hazards.
- This device is not suited for the operation in areas exposed to explosion hazards!
- Never lead explosive gases or gas mixtures into the device!
- Dependent on the model the device flammable gases may be led in the device. Check item „Glass ball filling“ in the device protocol. Flammable gases may be led in devices filled with glass balls. Here, the inside space of the housing is densely filled with glass balls ($\varnothing \sim 0.6\text{mm}$). In the unlikely case that a leakage caused an explosive atmosphere, the small spaces between the glass balls prevent a coincidental ignition caused by a further malfunction of the device from propagating.
- Never open the housing of the FTC300, especially because of the loose glass balls. When the device had been opened it may not work safely with flammable gases.
- Warranty expires if the housing is opened.
- The unit and the cables must be effectively protected against damage and against UV light (protective roof for outdoor installation).

1.3 Safety Instructions



- For safe operation of the device please pay regard to all instructions and warnings in this manual. Keep this manual for future use.
- Only put the device into operation after it has been installed properly. A competent and authorised person is required for installation, connection and operation of the device. This person has to read the manual and follow all instructions. Keep this manual to look up questions that can occur later on.
- Defective devices must be disconnected from the process! This applies for apparent damages of the device such as physical damages but also in the case of unclarified malfunctions in the operation. Separate the device from the process pneumatically (both gas inlet and gas outlet) and remove the power supply from the device.
- Make sure that the electric installation protection against accidental contact agree to the applicable safety regulations. The protective earth connection must be made before all other connections. Any interruption in the protective earth can cause danger.
- Pay regard to the local regulations and circumstances regarding electric installations.
- Repairs may only be done by Messkonzept.

1.4 Intended Use

Only gases that are non-corrosive and free of condensate, dust, aerosol or oil mist may be lead in the FTC-series gas analyzer. Flammable gases require appropriate protective measures. Explosive gases may not be lead into the FTC. The Instrument may not be used in hazardous areas. Please contact info@messkonzept.de for detailed information and solutions.

Upon installation the protection class has to be considered. The ambient atmosphere may not be corrosive. OEM-devices with protection class IP00 demand thermal and electric insulation, as well as mechanical protection for operation.

FTC-series gas analyzers do not have a metrology marking in the sense of EU directive 2014/32/EU. They may therefore not be used for example in analyzes in medical and pharmaceutical laboratories or in the manufacture of pharmaceuticals in pharmacies based on a doctor's prescription.

The specifications of the device and its manual have to be observed strictly. Please fill out questionnaire (2.01.1FB180619MPL1) for registration of your measuring task, if your intended use does not comply with intended use described above. Based on the information given in the questionnaire Messkonzept will examine the measuring task and possibly authorize it.

Chapter 2

Principle of Measurement

2.1 Determining Concentrations via Thermal Conductivity

Thermal Conductivity Detectors (TCD) are used in the chemical industry since the 1920s as the first process gas analyzers for the quantitative composition of gas mixtures. Every gas has a typical heat conductivity governed by its molar mass and viscosity. The measurement is based on the principle that the thermal conductivity of a gas mixture is dependent on the thermal conductivities of its gas components and their fractional amounts in the mixture. Thus, the concentrations of different components can be calculated from the thermal conductivity.

The main advantage of the TCD's measurement principle compared with the wide spread infrared analysis technique is, that it is not limited to gases with a permanent dipole moment. It can identify noble gases (He, Ar, Ne, etc.) as well as homonuclear gases such as H₂ and N₂. Furthermore, it is robust and cost effective.

The principle of thermal conductivity measurement works best if the analyzed gas components' thermal conductivities vary greatly. For TC measurement based analysis, one of the following conditions must be met:

- The mixture contains only two different gases (binary mixture), e.g. CO₂ in N₂ or H₂ in N₂
- The thermal conductivity of two or more components is similar, e.g. measuring H₂ or He in a mixture of O₂ and N₂ (quasi binary mixture)
- The mixture contains more than two gases, but all but two components' (or component groups') volumetric fractions are constant over time
- The mixture contains more than two gases, of which all but two components' concentrations can be determined through other measurement principles (as employed in the FTC 400 through cross-sensitivity compensation of IR- and TC-sensor information)

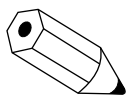

The thermal conductivity of gases rises with temperature and the slope of the increase with temperature is different for different gases. On customer request it can be checked whether the temperature of heat sink and/or source can be changed in order to improve the sensitivity of the measurement or to avoid cross-sensitivity effects.

Cross-sensitivity is the sensitivity of the measurement on other gases than the measured component. Perturbation-sensitivity means the sensitivity of the measurement on other influences than the gas-composition, e.g. the gas pressure.

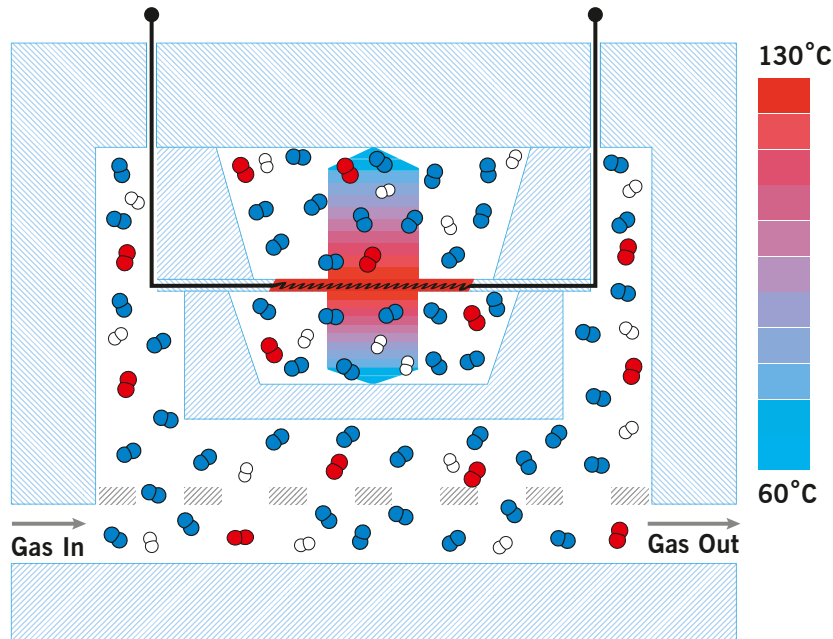

Figure 2.1: Schematic drawing of thermal conductivity measurement. The sensor is comprised in the stainless steel block which is kept at a constant temperature.

The FTC300 contains a thermal conductivity sensor to analyze the quantitative composition of gas mixtures. The measurement is based on the heat transfer between a heat source and a heat sink.

The measuring gas is led through a stainless steel block that is kept at a constant temperature of 63°C (for most applications). The block temperature is stabilized using a control loop - it serves as a heat sink of constant temperature. A micro mechanically manufactured membrane with a thin-film resistor serves as heat source. A control loop stabilizes the membrane temperature at 135°C (for most applications).

Above and below the membrane two small cavities are etched into the silicon. These cavities are filled with measuring gas by diffusion. The surfaces opposite to the membrane are thermally connected with the heat sink. Through maintaining a constant temperature gradient between the two opposite surfaces, the heat flow is dependant of the gas mixture's thermal conductivity alone. Hence the voltage needed to keep the membrane temperature constant is a reliable measure for the thermal conductivity of the mixture and can be used further to determine the gas mixture's composition.

Measuring Gas	Carrier Gas	Basic range	Smallest range	Smallest suppressed zero range	Multi Gas Mode
H ₂	N ₂ / air	0% - 100%	0% - 0.5%	98% - 100%	Yes
H ₂	Ar	0% - 100%	0% - 0.4%	99% - 100%	Yes
H ₂	He	20% - 100%	20% - 40%	85% - 100%	On request
H ₂	CH ₄	0% - 100%	0% - 0.5%	98% - 100%	On request
H ₂	CO ₂	0% - 100%	0% - 0.5%	98% - 100%	On request
He	N ₂ / air	0% - 100%	0% - 0.8%	97% - 100%	Yes
He	Ar	0% - 100%	0% - 0.5%	98% - 100%	Yes
CO ₂	N ₂ / air	0% - 100%	0% - 3%	96% - 100%	Yes
CO ₂	Ar	0% - 60%	0% - 10%	-	Yes
Ar	N ₂ / air	0% - 100%	0% - 3%	96% - 100%	Yes
Ar	CO ₂	40% - 100%	-	80% - 100%	Yes
CH ₄	N ₂ / air	0% - 100%	0% - 2%	96% - 100%	Yes
CH ₄	Ar	0% - 100%	0% - 1.5%	97% - 100%	Yes
O ₂	N ₂	0% - 100%	0% - 15%	85% - 100%	Yes
O ₂	Ar	0% - 100%	0% - 2%	97% - 100%	Yes
N ₂	Ar	0% - 100%	0% - 3%	97% - 100%	Yes
N ₂	CO ₂	0% - 100%	0% - 4%	96% - 100%	On request
NH ₃	H ₂	0% - 100%	0% - 5%	95% - 100%	On request
CO ₂	H ₂	0% - 100%	0% - 2%	99% - 100%	On request
SF ₆	N ₂ / air	0% - 100%	0% - 2%	96% - 100%	On request

Table 2.1: Measuring ranges of typical gas compositions for analysis with the FTC300.



The FTC300 must not be used with explosive gases. Flammable gases such as H₂ and CH₄ may only be used in devices filled with glass balls. A gas mixture of a flammable gas with an inert gas in a mixing ratio such, that it is still inflammable for any amount of air added is called totally inertised. Totally inertised gases can also be used in devices without glass balls.

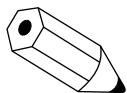

“Basic range“ is the largest possible measuring range and is set by default. The linearization is performed over the basic range. The smallest measuring ranges at the beginning and the end of the basic range are facilitated through specific calibration. The smallest possible range between the basic range and the smallest ranges at the end beginning and the end of the range can be estimated by linear Interpolation.

Measuring ranges can be set up in the “Current Loop“ menu, see Section 8.4.1

The Multi Gas Mode (MGM) is a configuration that allows for the consecutive measurement of different gas pairs. The gas pair can be switched through the control panel or via the RS232-interface. Gas pairs labeled “Yes“ in Table 2.1 are commonly used. Gas mixtures labelled “On request“ can also be implemented upon request.

Chapter 3

Assembly of the Instrument

3.1 FTC300 Detector Unit

The FTC300 detector unit consists of a hermetically sealed pressure proof stainless steel block with a gas duct, which is suited for pressures up to 20 bar. Sample gas entering through the gas inlet is guided to the micro-mechanical thermal conductivity sensor and further downstream to the outlet port. In particular the pneumatics are designed to minimize the influence of a changing gas flow. The operating temperature of 63°C is stabilized by a highly accurate PI control loop.

In order to avoid electrical interference on the measuring output the high performance analog adaptation circuit is directly mounted on top of the stainless steel block. The piggyback-mounted processor board digitizes the signal in a 24bit A/D converter. The micro-controller performs all calculations, as linearization, calibrations and cross sensitivity compensation directly on the detector unit.

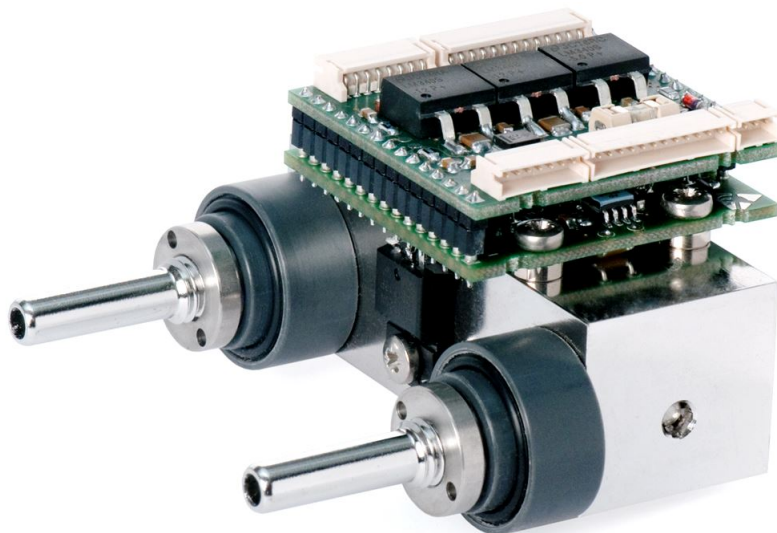

Figure 3.1: FTC300 Detector Unit

3.2 Installation of the FTC300

The FTC300 is designed for wall fastening. The four mounting holes are shown in Figure 3.2. M4 cylinder head bolts are suitable. Please remember to keep additional space for adequate assembly of gas hoses and cables (see Chapter 12 "Appendix: Dimensional Drawing" for more information).

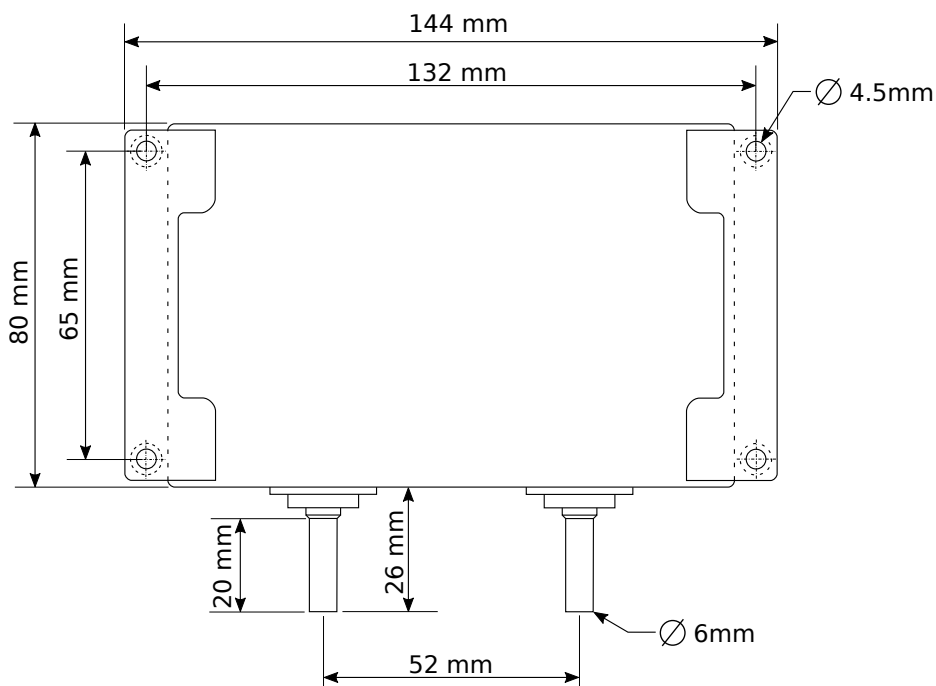

Figure 3.2: Mounting holes shown from the reverse side of the housing



If you are planning to lead flammable or toxic gases into the device, the device must be installed in a well ventilated area. All devices undergo a leakage test during production, nevertheless a limited release of small gas quantities is possible.

3.3 Gas Ports

On the bottom of the FTC300 housing two tubes with 6mm outer diameter for gas connection are located. They are labeled with "GAS IN " and "GAS OUT".

For low requirements regarding gas tightness and resistance to pressure the tubes can be used as hose connector. For permanent gas and pressure tightness compression fittings are recommended (e.g. by "Swagelok"®).

After connecting the device a leakage test should be performed (especially when working with flammable and/or toxic gases).

3.4 Electrical Connectors and Ground

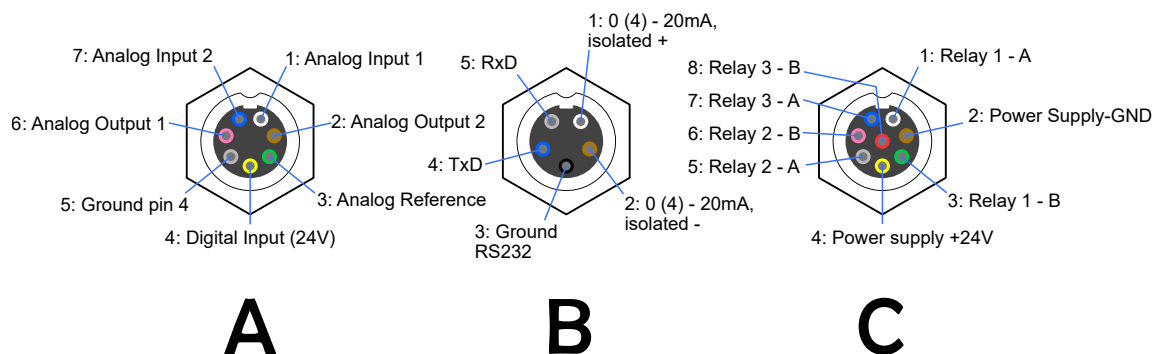

Figure 3.3: Electrical connector pin assignments of the three connectors on the FTC300

The FTC300 has three three plug connectors as shown in Figure 3.3. Further information on the function of each contact is given in Table 3.1. The cables (712, IP67) with molded connector plug and a length of two meters (five meters available on request) are part of the purchased parts package. The cables have open ends. The cross-section of the conductors in cable A and C is $0,14\text{mm}^2$, for cable B $0,25\text{mm}^2$. Cable A is shipped with devices set up for analog output.



The protection class of the device is only effective with all cables attached. In case cable A is not used, connector plug A has to be closed with an end fitting.

Pin No.	Wire colour	Function	Description
Connector A (7 pins)			
1	white	Analog Input 1	0 to 10V, 24 bit resolution
2	brown	Analog Output 2	0 to 10V, 16 bit resolution
3	green	GND	GND for pins 1, 2, 6, 7
4	yellow	Digital Input (DIN)	low: <4.6V; high: >11.4V
5	grey	GND	GND for Pin 4
6	pink	Analog Output 1	0 to 10V, 16 bit resolution
7	blue	Analog Input 2	0 to 10V, 24 bit resolution
Connector B (5 pins)			
1	white	Current Loop +	0 (4) to 20mA, floating isolated $\pm 500V$ to ground, max. 1000 Ohm burden 16 bit resolution
2	brown	Current Loop -	
3	black	Serial Interface RS232	GND for pin 4, 5
4	blue	Serial Interface RS232	TxD (transmit data)
5	grey	Serial Interface RS232	RxD (receive data)
Connector C (8 pins)			
1	white	Relay 1	isolated contact; max 30V, 0.5A
2	brown	Power supply -	GND
3	green	Relay 1	isolated contact; max. 30V, 0.5A
4	yellow	Power supply +	+ 24V (18V to 30V), max. 700mA
5	grey	Relay 2	isolated contact; max. 30V, 0.5A
6	pink	Relay 2	isolated contact; max. 30V, 0.5A
7	blue	Common Relay 3	isolated contact; max. 30V, 0.5A
8	red	Common Relay 3	isolated contact; max. 30V, 0.5A

Table 3.1: Connecting pin assignment of connectors A, B, C

3.4.1 Requirements for Electrical Connectors



Before using the device make sure that the power supply is in accordance with the specifications of the device and that all electric connections correspond to the information given in this manual.

The FTC300 is a device with protection class III. Relay contacts and inputs should only be operated with safety extra low voltage (SELV;4kV). The power supply has to comply with the PELV specification (protective extra low voltage) according to EN 60204-1. Unlike SELV, PELV may be grounded at the output side.

3.4.2 Ground

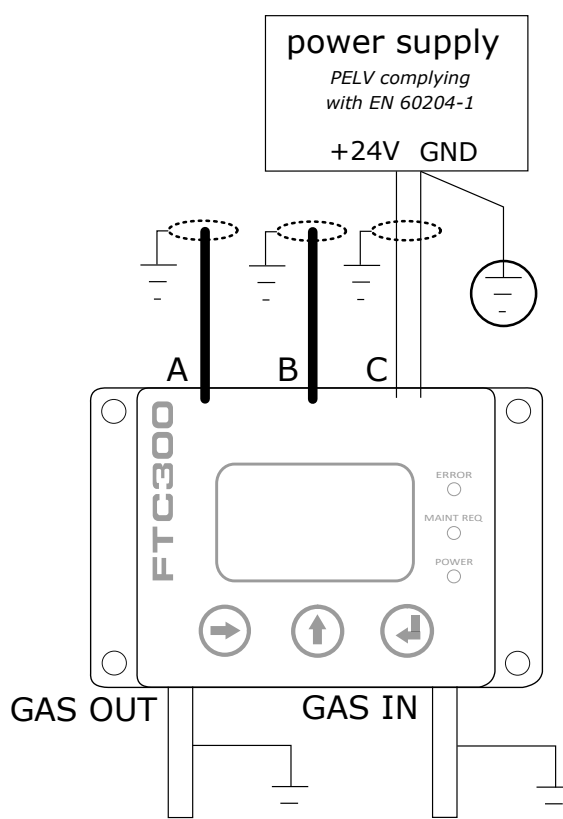

Figure 3.4: Grounding the FTC300

To comply with EN 60204-1 and to ensure your device's function, the device has to be installed such that the power supply (PELV) is connected to protective earth (PE) with its ground conductor, see Figure 3.4. The shielding of cables A, B and C should be connected to functional ground. Dependent on the circumstances, gas inlet and gas outlet can be grounded in addition. Connections to ground should be made with short low-resistant cables of large diameter.

3.4.3 Data exchange via serial interface (RS-232)

The serial interface, often called UART (Universal Asynchronous Receiver Transmitter), is based on the RS-232 standard. The point-to-point data transmission is carried out via the two TxD- (Transmit

Data) and RxD- (Receive Data) wires to be crossed with a common ground line (GND) for both devices. This creates a bidirectional bus that allows full-duplex communication. The communication partners can therefore send and receive data simultaneously.

Data transmission via UART is performed with a fixed data frame (UART frame). This frame must be known to both communication partners. It consists of: A start bit, 5-9 data bits, an optional parity bit and one or two stop bits. If a PC is connected to the analyzer, the necessary settings are typically identified automatically. If this is not the case, the parameters can be set manually according to Table 10.2. (see Section 10.1).

Only a few PCs are still delivered with a so-called COM port (serial RS-232 interface). In order to be able to operate and program devices that have an RS-232 interface with computers without this, use of converters from RS232 to USB is advised. The converters often have a 9-pin D-Sub connector as input, but there are also converters with screw terminal connections.

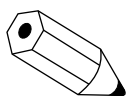

The serial interface allows operation of the instrument and the display and storage of measurement data with the SetApp program. More information and a link to download the software can be found at www.messkonzept.de.

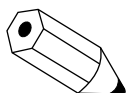

If you plan to develop or use your own software solutions for communication via the RS-232 interface, you may need more detailed information on the available parameters, etc. Please contact Messkonzept in this regard.

Chapter 4

The Front Panel

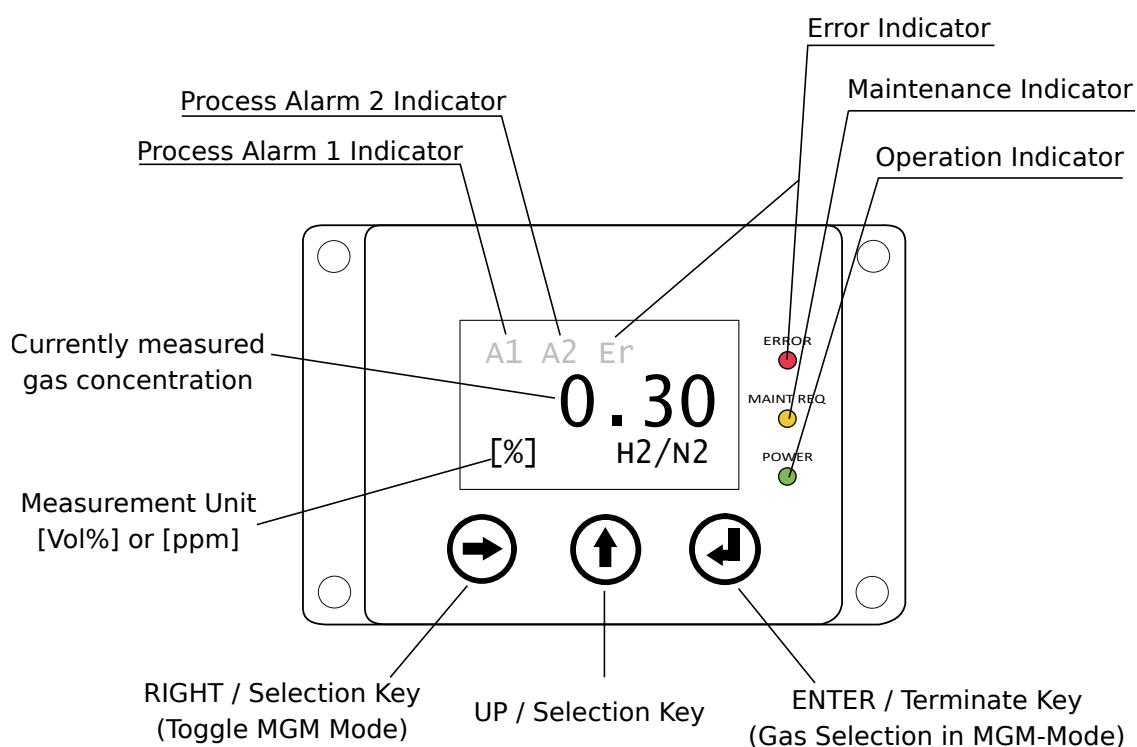

Figure 4.1: Front view schematic of the FTC300 front panel

4.1 Display

4.2 LED Indicators

System Alarm Indicator (red)

The flashing red LED indicates a system error. System error indication depends on the configuration of the "Alarm matrix". Please see Section 8.3.7 "Common Relay" to configure alarm triggers for your application. Standardly internal errors (see Chapter 9 "Appendix: System Errors") trigger the system alarm.

System Maintenance Indicator (yellow)

The flashing yellow LED indicates that the instrument demands maintenance. The device still works but its specifications (see Section 10.1) might not be met anymore.

Operation Indicator (green)

The flashing green LED indicates that power is supplied and the internal processor works.

4.3 Keys

RIGHT / Selection Key

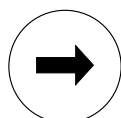

The <RIGHT> key enables the operator to scroll through the various menu items of menus and submenus. The currently selected menu item is marked by black background and is called with the <ENTER> key.

In submenus requiring numerical inputs, the <RIGHT> key scrolls to the next digit and to "ESC/OK" at the end.

UP / Selection Key



In menus or submenus the <UP> key quits the recent menu and brings you back to the menu above and ultimately to the main menu.

To quit menus with an "ESC/OK" option, select one of these fields with the <RIGHT> key and confirm with <ENTER>.

In submenus requiring numerical inputs, the <UP> key changes the selected digit.

ENTER / Termination Key

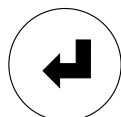

The <ENTER> key calls the item that is marked as selected (selection is indicated through black background highlighted text). Menu items are selected by the <RIGHT> key. In submenus with an "ESC/OK" option the <ENTER> key confirms the selection of "ESC" or "OK".

Optional: Devices with Multi Gas Mode (MGM)

To quickly change the selected gas pair from the operational/main screen, press the <RIGHT> key once to activate the quick access mode (Note that the selected gas pair is highlighted by a black background colour when quick access is activated). In the quick access mode, the <ENTER> key allows you to toggle to the next gas pair in the MGM list. Press <ENTER> repeatedly until the desired gas pair (e.g. "H2/N2") is selected. Pressing the <RIGHT> key will deactivate the quick access mode again.

See Section 8.2.4 "Multi Gas Mode List (only with MGM-option)" for more information on the MGM list.

Chapter 5

Switching on the device

This chapter describes the device start-up routine. The warm up screen, see Figure 5.1, shows the block temperature while the block warms up. After the warm up, the device switches to the operation screen, see Figure 5.2. From the operation screen the main menu can be opened.

The device can be run in two different modes: in the safety mode or in normal mode. In the safety mode every action has to be confirmed by the operator code (default: 111.000). Also in normal mode, certain actions require an expert code, for example when changing the operator code and changing between normal and safety mode. This manual refers to the device operated in normal mode.

5.1 Warm up Screen

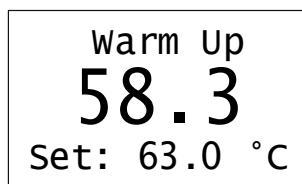
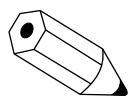

Figure 5.1: warm up screen of the FTC300

The warm up screen shows the current block temperature during warm up in the center of the screen (see Figure above). The target value of the block temperature, 63 °C for the standard version or 70 °C for the high temperature version, is shown in the bottom line of the screen. The current loop, relays and analog outputs are deactivated during warm up. When the difference between the measured temperature and the target temperature is smaller than 0.6 K, the device switches to the operation screen.



Pressing the <UP> key during warm up switches directly to operation screen and activates the current loop. The displayed concentration value will not be precise until the needed block temperature is reached.

5.2 Operation Screen

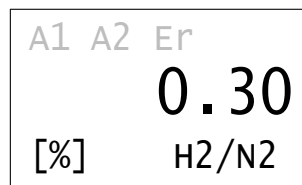

Figure 5.2: FTC300 operation screen

After warm up the operation screen is shown (see Figure above).

In the center of the display the currently measured gas concentration is shown, the associated unit of the measurement (ppm or Vol.%) is indicated in the bottom left corner of the operation screen. The currently measured gas pair, e.g. "H2/N2" for hydrogen in nitrogen, can be found in the bottom right corner of the display. The display resolution in ppm is 1 ppm, the number of digits displayed in Vol.% indication is adjusted according to your requirements upon shipment (can be changed manually in the Expert mode, see Sections 8.2.1 and 8.5.1).

In the top display line status information may be shown: Alarms are indicated by "A1" and "A2", system errors are indicated by "Er", see Section 8.3 "Relay Setup" and Chapter 9 "Appendix: System Errors" for more information. If the top display line is empty there are no active alarm indications.

From the operational screen the main menu can be opened using the <UP> key.

5.3 Top Level Main Menu

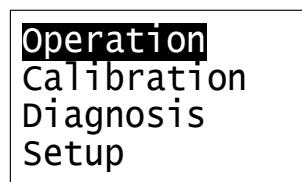

Figure 5.3: main menu of the FTC300

Press the <UP> key to get access to the top level main menu.

The main menu is the origin of the menu tree that gives access to the submenus, see Chapter 11 for the complete menu tree. Selecting "Operation" (as shown in Figure 5.3) and pressing <ENTER> or simply pressing <UP> returns to the Operation screen. To access the submenus, select the desired submenu by pressing the <RIGHT> key and press <ENTER>.

The menu paths shown in the following chapters all start from the main menu.

Chapter 6

Calibration

6.1 General Information on Calibration

For devices operated in “safety mode“, the operator code is required to access the calibration menu. By default the operator code is set to 111.000.

We recommend a calibration, resp. a check of the calibration if one of the following criteria is met:

- After bringing the device into service
- On a regular cycle, depending on the precision aimed for. To find out the appropriate time between calibrations, we recommend to begin with a more frequent check of the calibration. The time between calibrations can range between:
 - several month for a measuring task in the Vol.% range
 - days to weeks for a measuring task in the sub-Vol.% range
 - directly before every measurement if highest accuracy is needed
- When the situation of the measurement regarding pressure, temperature or gas flow changes

The goal of the calibration is that the measured concentration is in agreement with the given test gas concentration. To obtain this, two calibration parameters that correspond to the offset/zero and the gain/span of a linear equation are available. A two-point calibration requires two test gases. Both calibration parameters, offset and gain, are adjusted. The concentration of the test gases does not have to meet the beginning and the end of the measuring range, a difference of $\pm 10\%$ is permitted.

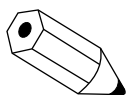

The menu sequence is designed such that prior to a gain always an offset calibration has to be done first. Usually a single point calibration determining a new offset value is sufficient to obtain a good calibration.

In the case of one point calibration, a test gas of any concentration in the measuring range is feasible. For two point calibrations it is preferable to use the gas concentrations at the lower and upper end of your measuring range.

6.1.1 Calibration gas purities and flooding time

Messkonzept uses gases with the following purities for calibration:



File name:

FTC300 Manual 1.09KD140704CWI1V05.pdf

H ₂	He	N ₂	Ar	O ₂	CO ₂	CH ₄
5.0	5.0	5.0	4.6	4.5	4.5	4.5

Table 6.1: Recommended calibration gas purities

These gas purities are selected such that the devices comply with the specifications for the smallest measuring ranges feasible with the FTC300. Messkonzept recommends gases of same purity for calibration on-site. For differing individual requirements, opt for an appropriate gas purity.

To achieve good calibration results, make sure that the instrument is completely flooded with the calibration gas before starting the calibration measurement (sampling). The required running-in time depends strongly on the volume to be flooded (especially dead volume) before the measuring device and the flow rate. For small tube volumes (<100 ml) and a flow rate of 60 l/min, a running-in time of a few minutes (medium accuracy requirements in a large measuring range) up to one hour (very high accuracy requirements in a small measuring range) is recommended.

Please contact Messkonzept if you have questions about calibration gas selection or calibration setup.

6.2 Set Offset Gas Concentration

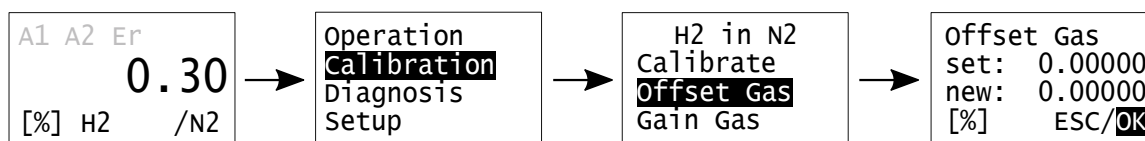

Figure 6.1: offset gas setup menu

Before performing a calibration, the concentrations of the used test gases have to be set. In the submenu "Offset Gas" the used concentration of the offset gas has to be entered. Select the submenu "Offset Gas" by pressing the <RIGHT> key and press <ENTER> to open the menu for the numerical entry. Enter the offset calibration gas concentration by changing each digit to the desired value. The position of the cursor in the number is moved by the <RIGHT> key, the value of the digit (0-9 or . for the decimal separator) at the current position of the cursor is changed with the <UP> key. When the correct value is set, move the cursor to "OK" and confirm with <ENTER>.

6.3 Set Gain Gas Concentration

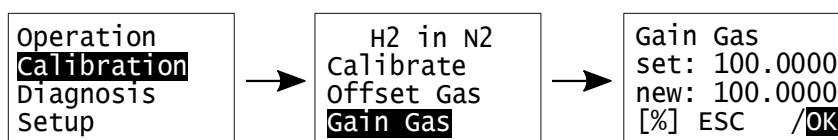

Figure 6.2: gain gas setup menu

Prior to a two point calibration, the gain gas concentration has to be set in the submenu "Gain Gas". This menu is operated analogously to the "Offset Gas" menu described in Section 6.2.

6.4 Offset Calibration

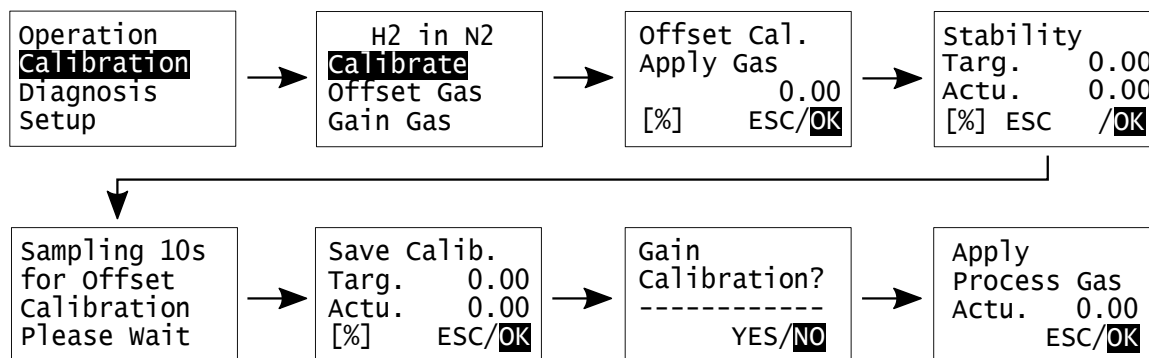

Figure 6.3: menu path if only offset is calibrated

After opening the menu “Calibrate“, you are asked to apply the offset test gas. The third line of the display shows the test gas concentration as set in the “Offset Gas“ menu (see Section 6.2). Please calibrate using the same/a similar flow rate as in your process measurement situation. Confirming with “OK“ leads to the menu “Stability“. The second line contains the set test gas concentration (“Targ.“), the third line the measured concentration (“Actu. “) using the current (unchanged) calibration. Before continuing, wait for a sufficient running-in time to evacuate possible disturbing gases from the device. Only continue if the value of the actually measured concentration reaches a final value (you might observe some signal noise around a constant value). To start the calibration sampling, select “OK“ and press <ENTER>. The sampling phase of 10s is started. Based on the average measured concentration, the new offset is determined such that the currently measured (and calibrated) value accords with the given test gas concentration within the specifications of the device. Repeat the calibration in case the measured concentration after calibration is not in agreement with the test gas concentration. By selecting “ESC“ and pressing <ENTER>, the offset calibration is repeated. With “OK“ the calibration is confirmed as correct and the new offset value is saved.

The following menu offers the option to proceed with the gain calibration. Choosing “YES“ leads to the gain calibration menu described below. It is highly recommended to select “NO“ at this point. The gain value is very stable over time. Faulty gain calibration may worsen the device’s performance. After quitting the calibration, you are asked to apply process gas again, giving you time to restore your typical process measurement environment while error warnings are deactivated and relays stay frozen (see Section 8.3.5 if you wish to set up relays to be frozen during calibration).

6.5 Gain Calibration

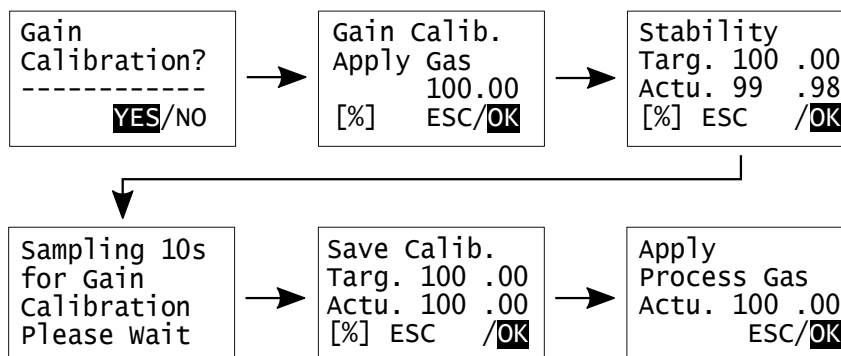

Figure 6.4: menu path of the gain calibration

The menu structure is designed such that the gain calibration procedure is only accessible after an offset calibration. The steps of the gain calibration correspond to the offset calibration described above (of course now using a different gas concentration, as set up in the "Gain Gas" menu, see Section 6.3). Again, please remember to wait for a sufficient running-in time to evacuate possible disturbance gases. The gain calibration can be canceled in any sub-menu by selecting "ESC". If gain calibration is canceled, the previous slope of your calibration line remains unchanged.

6.5.1 Use of Substitute Gases

Instead of using toxic or explosive gases for calibration, substitute gases may be used. A substitute gas has (at a certain concentration) the same thermal conductivity as the test gas it is substituting, such it can also be used for the calibration instead. Please contact Messkonzept for details on possible substitute gases for your application.

Chapter 7

Diagnosis

The FTC300 has several integrated diagnosis and test functions that can be accessed through the diagnosis-menu. The menu provides the following functions:

- A parameter menu in which device-internal parameters/variables can be read out
- An error menu in which pending errors are listed

For devices operated in “safety mode”, the operator code is needed to access the diagnosis menu. By default the operator code is set to 111.000.

7.1 Parameter Menu

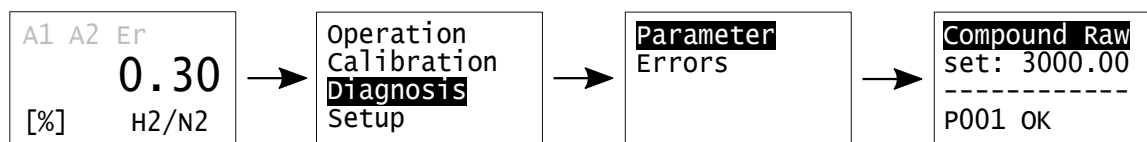

Figure 7.1: parameter menu for advanced diagnosis

The configuration of the FTC300 is defined by a list of internal parameters. The “Parameter“ menu gives read-only access to these parameters. This may help an experienced user to diagnose malfunctions caused by wrong settings. The parameter menu allows you to scroll through the entire parameter list. Contact Messkonzept for detailed information on the listed parameters. The first display line contains the name of the parameter, in the second line the parameter value is shown. The last line shows the parameter index. To move forward in the list, press <ENTER>, to move backwards, press <Up>. To leave the parameter menu mark <OK> by pressing <RIGHT> and confirm with <ENTER>. Some parameters can be changed in the expert setup, see Section 8.5 for more information.

7.2 Errors

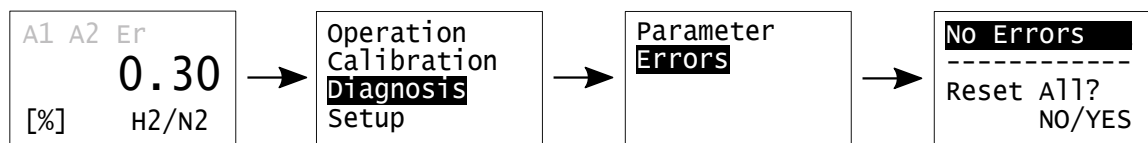

Figure 7.2: error menu

When the device is in the measuring mode or calibrating, several parameters are continuously checked for plausibility. The parameters checked, the list of possible errors and the ranges defining a plausible value can be found in Chapter 9 "Appendix: System Errors".

Errors are indicated by a flashing red light on the front panel and "Er" written in the first line of the operation screen. In the default setting also the "common relay" will signalize the error externally (see Section 8.3.7). The menu "Errors" gives access to the list of current errors. "No Errors" indicates that no error is pending, for pending errors the name of the error is given. Pressing <ENTER> proceeds to the next pending error and <UP> to the previous error. To leave the error menu press <RIGHT> once or twice to select "NO" or "YES" and the <ENTER> key to confirm your selection. An error reset will affect maintenance-warnings only - all other errors and warnings are continuously monitored and automatically reset when the error no longer persists.



Defective devices must be disconnected from the process! This applies for apparent damages of the device such as physical damages but also in the case of unclarified malfunctions in the operation. Separate the device from the process pneumatically (both gas inlet and gas outlet) and remove the power supply from the device.

Chapter 8

Setup

For devices operated in “safety mode“, the operator code is required to access the setup menu. By default the operator code is set to 111.000.

8.1 The Setup Menu

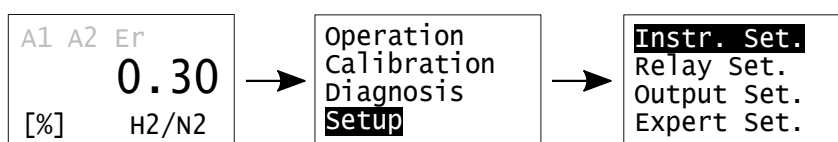

Figure 8.1: FTC300 setup menu

The “Setup“ menu contains four submenus:

- “Instrument Setup“: select the measured gas pair, the units and the T90 response time of the exponential filter
- “Relay Setup“: define the conditions to trigger the relays
- “Output Setup“: properties of the external signal channels for analog output
- “Expert Setup“: grants write access to parameters, reset functions, access modes/codes and test signals for subsequently connected equipment

8.2 Instrument Setup

8.2.1 Display Unit

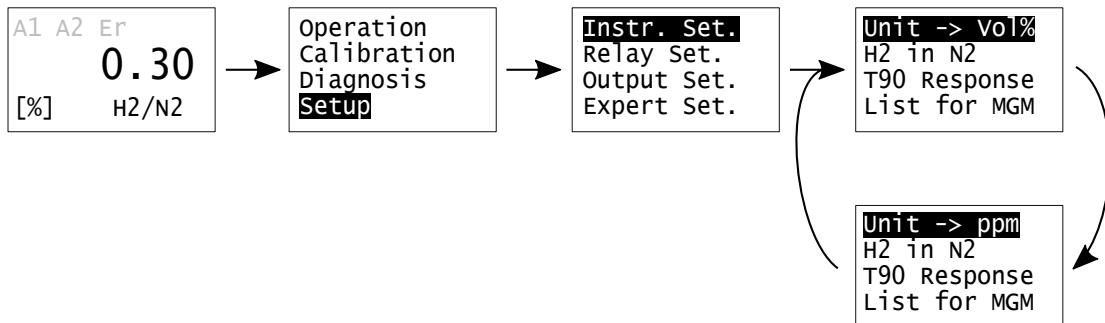

Figure 8.2: changing the displayed unit for gas concentrations

The first item of the instrument setup menu allows selection of the display unit. Pressing <ENTER> alternates the unit between ppm and Vol.%. Quit the menu with the <UP> key. The value of parameter P76 (see Section 8.5.1) sets the number of digits after the decimals point between 1 and 4 when the display unit is set to Vol.%. The resolution in ppm is always 1 ppm. All internal calculations of the FTC300 are done in ppm. Values retrieved through the RS-232 interface will always be in ppm with 1ppm resolution.

8.2.2 Measuring Gas Setup

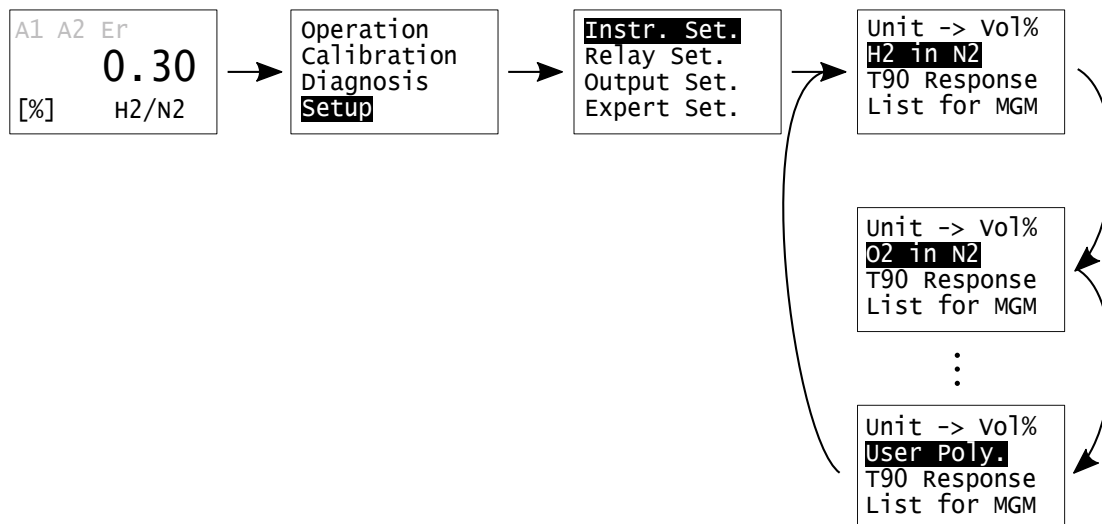

Figure 8.3: measuring gas setup

The second line of the instrument setup menu indicates the currently measured binary gas mixture. For devices with Multi-Gas-Mode (MGM) pressing <ENTER> changes to the next linearization curve included in the device. Up to 16 binary gas mixtures' linearization curves can be included. For every binary gas mixture the corresponding set of linearization parameters and the last used calibration for the selected linearization are automatically used. The settings of relays, the scaling of the analog outputs and the measuring range do not change when using different binary gas mixtures.

8.2.3 Response Time Setup

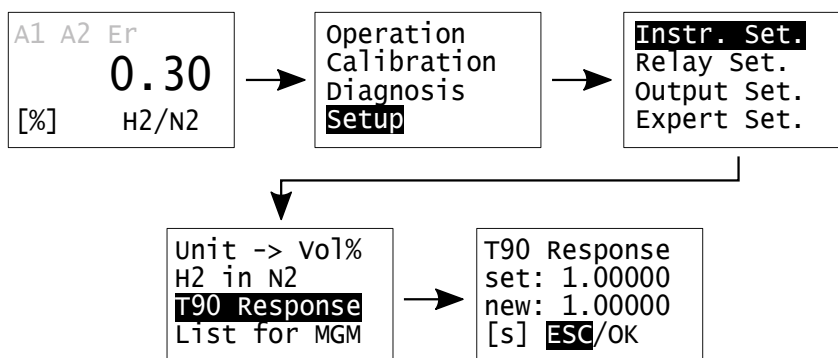
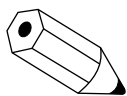
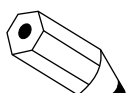

Figure 8.4: T90 response time setup

In the menu “T90 Response“ the response time of the exponential filter can be adjusted. The filter reduces the influence of fast variations of the raw signal (signal noise smoothing). The numerical value for the T90 response time is given in the unit of seconds. A range between 0s and 100s is permitted for this value, reasonable values lie between 0.5s to 10s. You can change the numerical value by navigating through the digit position using the <RIGHT> key and changing it using the <UP> key. Confirm by pressing the <UP> key until “OK” is selected. The changed value can be discarded by selecting “ESC” instead. Setting “T90 Response“ to 0.0 turns the exponential filter off.



The true response time is influenced by the gas exchange time which depends on the pneumatic installation and the flow rate of measuring gas. A gas flow of 80l/h leads to a gas exchange time of under 0.5s measured from the gas inlet of the device. Note that the response time in your process depends greatly on the upstream volume before the FTC300. Shorter and/or thinner tubing will benefit response times.



The T90-time is the time, in which a sudden change of the measurand (e.g. the gas concentration) reaches 90% of it's final value.

8.2.4 Multi Gas Mode List (only with MGM-option)

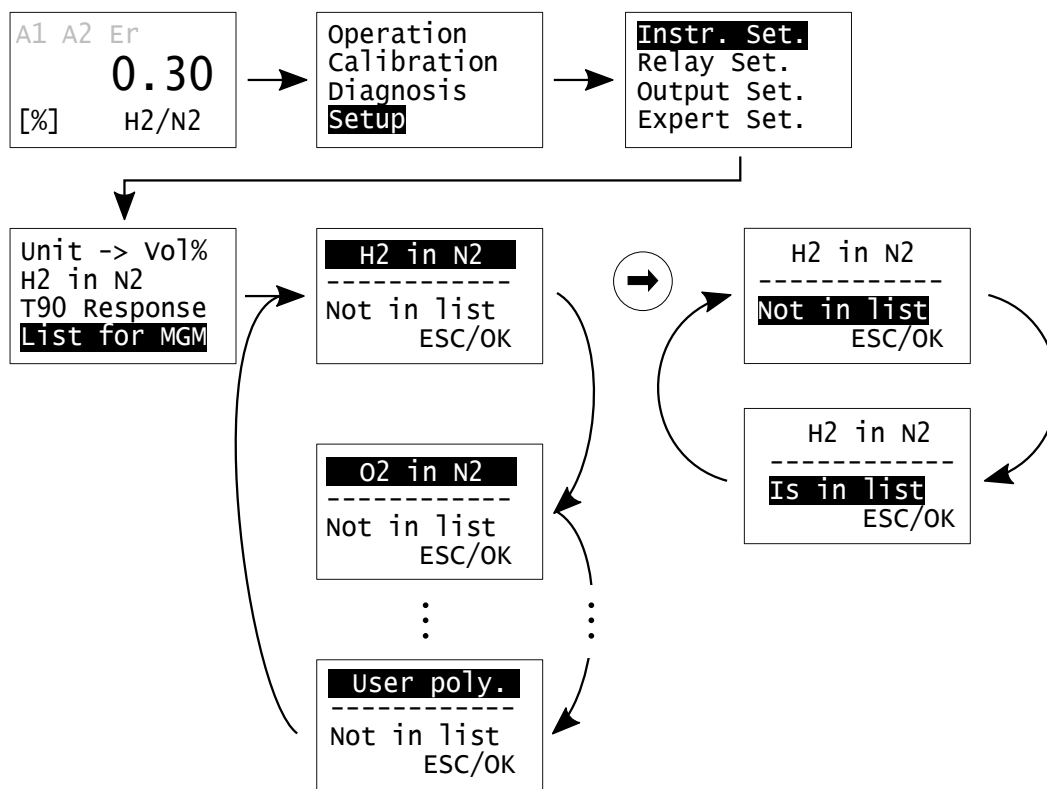
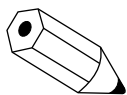

Figure 8.5: gas pair selection in Multi Gas Mode

Devices supporting the Multi Gas Mode (MGM) can measure (in succession) up to 16 different binary gas mixtures following your wishes when ordering the FTC300. From the list of all available binary gas mixtures a list for the short-key access from the operational screen, further called “List for MGM“, can be edited. Binary gas mixtures can be added to or removed from the “List for MGM“; gas mixtures labelled with “Is in list“ are included in the short list. Toggle through the available binary gas mixtures using the <ENTER> or the <UP> key. The <RIGHT> key changes to the third display line, where the <ENTER> key is used to switch between “Is in list“ and “Not in List“. Press <RIGHT> to select “OK“ and <ENTER> to confirm the selection.



From the operational screen (main screen showing the currently measured gas concentration) you can quickly toggle through the set-up MGM short list: Press <RIGHT> once to activate the quick access and then press <ENTER> until you read the desired gas pair name from the short list in the bottom right corner of the screen. Pressing <RIGHT> again deactivates the quick access.

8.3 Relay Setup

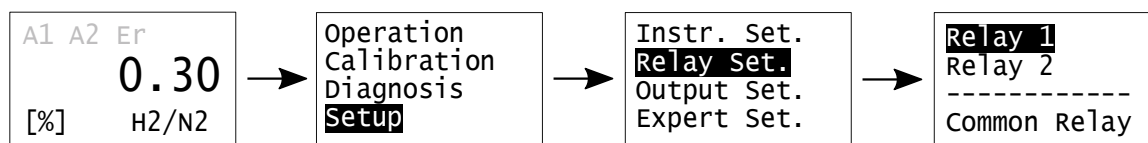
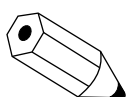

Figure 8.6: selection of configurable relays

The menu “Relay Setup” gives access to the configuration of the two process alarm relays “Relay 1”, “Relay 2” and the status alarm relay “Common Relay”. The thresholds and hysteresis for “Relay 1” and “Relay 2” can be set. The status relay indicates a malfunction of the device, but can also indicate the threshold alarms. Each relay may be configured as failsafe or not failsafe.



The threshold relays are indicated by “A1” respectively “A2” in the first display line of the operation screen. The common relay is indicated by “Er” in the first display line of the operation screen and also by the flashing red LED on the front panel.

8.3.1 Relay 1 Mode

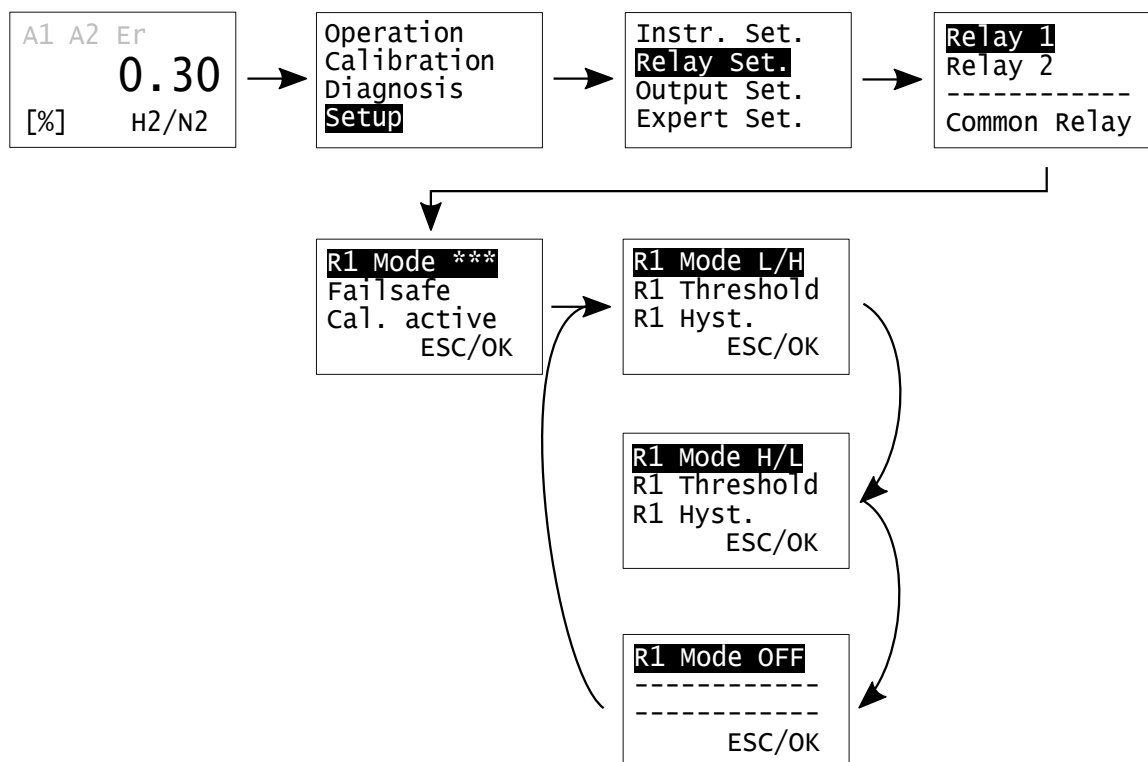

Figure 8.7: relay mode setup

Relay 1 can be operated in different modes described below. Selecting “Relay 1” and pressing <ENTER> gives access to the different modes:

- “R 1 Mode L/H“: signalling from low to high. When the measured concentration increases and reaches the threshold, the alarm is active until the measured concentration decreases again below the threshold minus a hysteresis value. The hysteresis value is specified in percent of threshold (can be set to 0%).
- “R 1 Mode H/L“: signalling from high to low. When the measured concentration decreases and reaches the threshold, the alarm is active until the measured concentration increases again above the threshold plus a hysteresis value. The hysteresis is specified in percent of threshold.
- “R 1 Mode OFF“: Limit value alarm is deactivated, the relay is not used.

8.3.2 Relay 1 Threshold

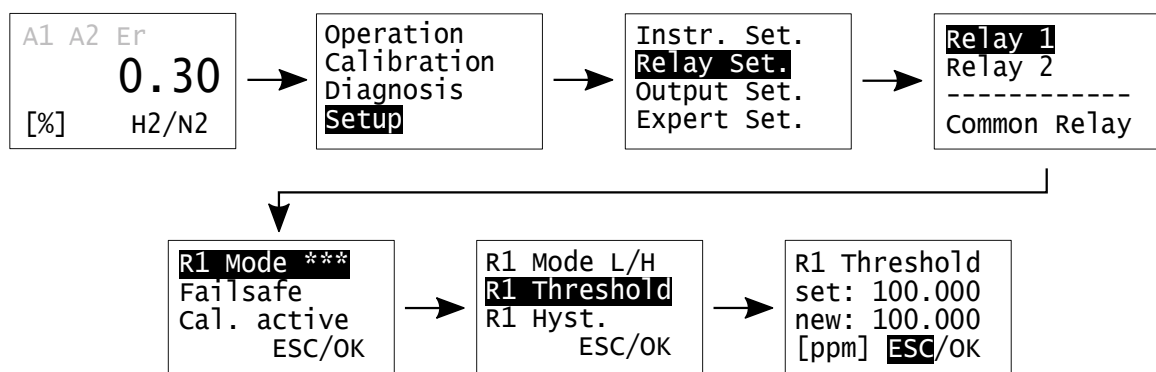

Figure 8.8: Relay 1 threshold configuration

In the “R1 Threshold“ menu the threshold value is set. The value is set in the currently used measuring unit (ppm in this case). The threshold is independent of the measuring range.

You can navigate to the digit position you wish to change using the <RIGHT> key. A digit’s value can be changed using the <UP> key. To confirm your entry, press the <RIGHT> key several times until “OK“ is highlighted and press <ENTER>. Selection of “ESC“ will discard made changes.

8.3.3 Relay 1 Hysteresis

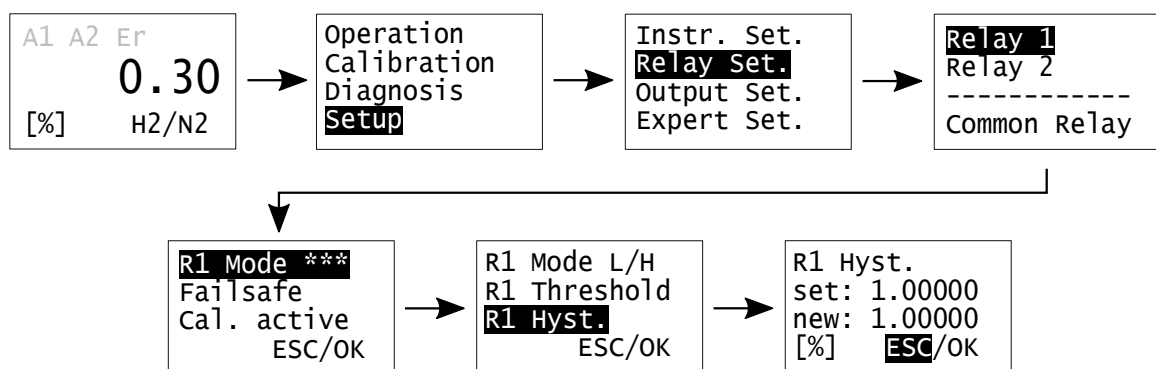

Figure 8.9: Relay 1 hysteresis configuration

In the "R1 Hysteresis" menu the hysteresis value for the reset of the relais can be configured. The value is given in percent of the threshold value.

You can navigate to the digit position you wish to change using the <RIGHT> key. A digit's value can be changed using the <UP> key. To confirm your entry, press the <RIGHT> key several times until "OK" is highlighted and press <ENTER>. Selection of "ESC" will discard made changes.

8.3.4 Relay 1 failsafe / Not failsafe

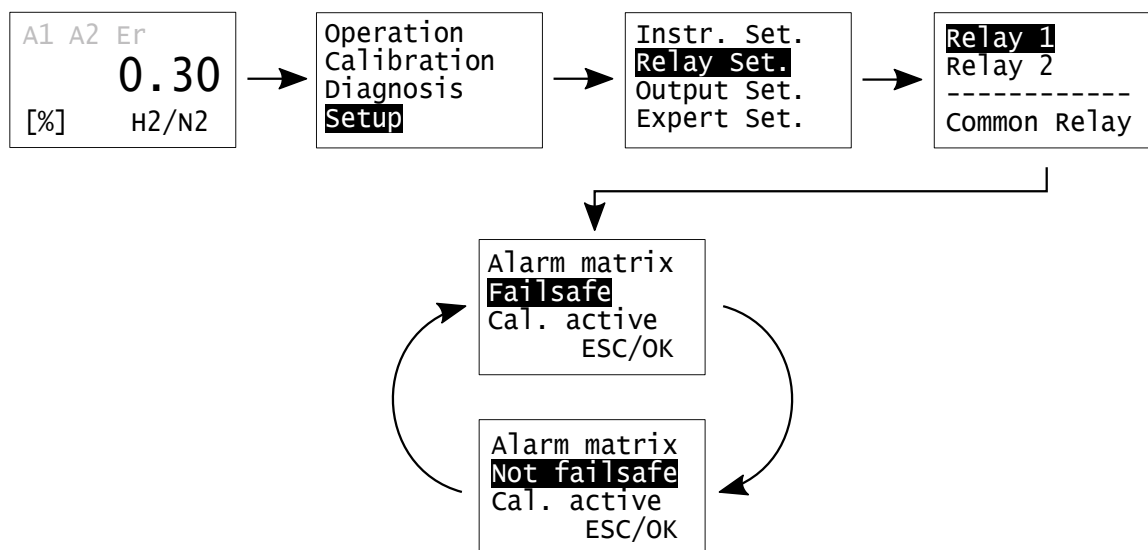

Figure 8.10: Toggling between relay "Failsafe" and "Not failsafe"-mode

The threshold alarms can be configured as "Failsafe" or "Not Failsafe". "Failsafe" means that the relay is live with no error pending. Hence, the alarm is indicated if the threshold is reached or if the closed-circuit contact is interrupted. "Not Failsafe" means that the relay is open with no error pending and closes when an error appears. Press <ENTER> to switch between "Failsafe" and "Not Failsafe". The change is made effective by pressing <RIGHT> three times to mark "OK" and confirmed with <ENTER>.

8.3.5 Relay 1 active/frozen during calibration

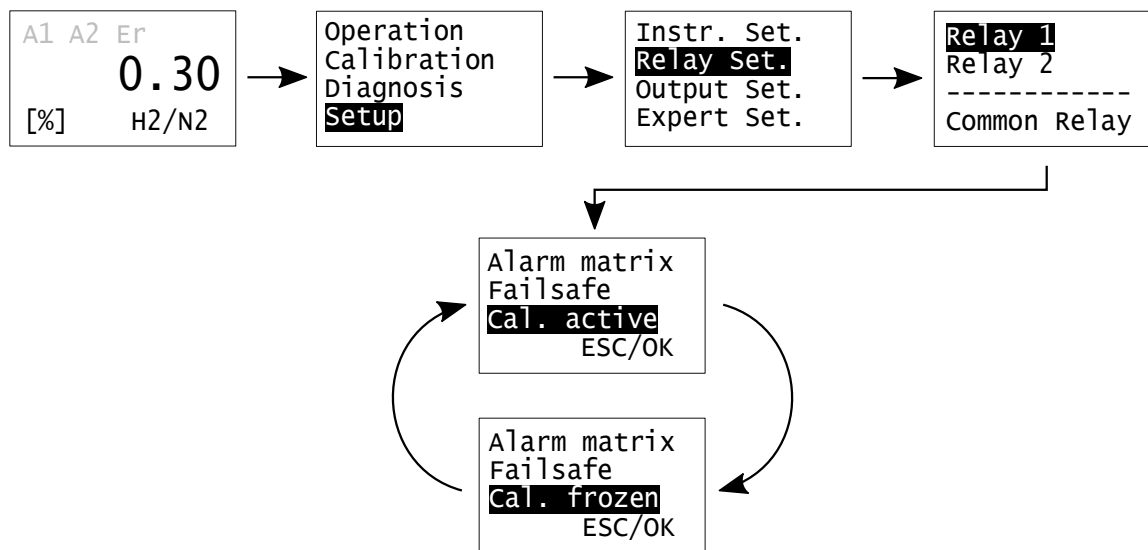

Figure 8.11: Setup of relay behaviour during calibration

The relays can be configured as “Calibration active” or “Calibration frozen”. With “Calibration frozen” the relay does not respond to any changes of the measured concentration during the calibration procedure and stays in the state it was in when the calibration began. With “Calibration active” the relay acts according to its current settings during calibration. Press <ENTER> to switch between “Calibration frozen” and “Calibration active”. The change is made effective by pressing <RIGHT> two times to mark “OK” and confirming with <ENTER>.

8.3.6 Relay 2

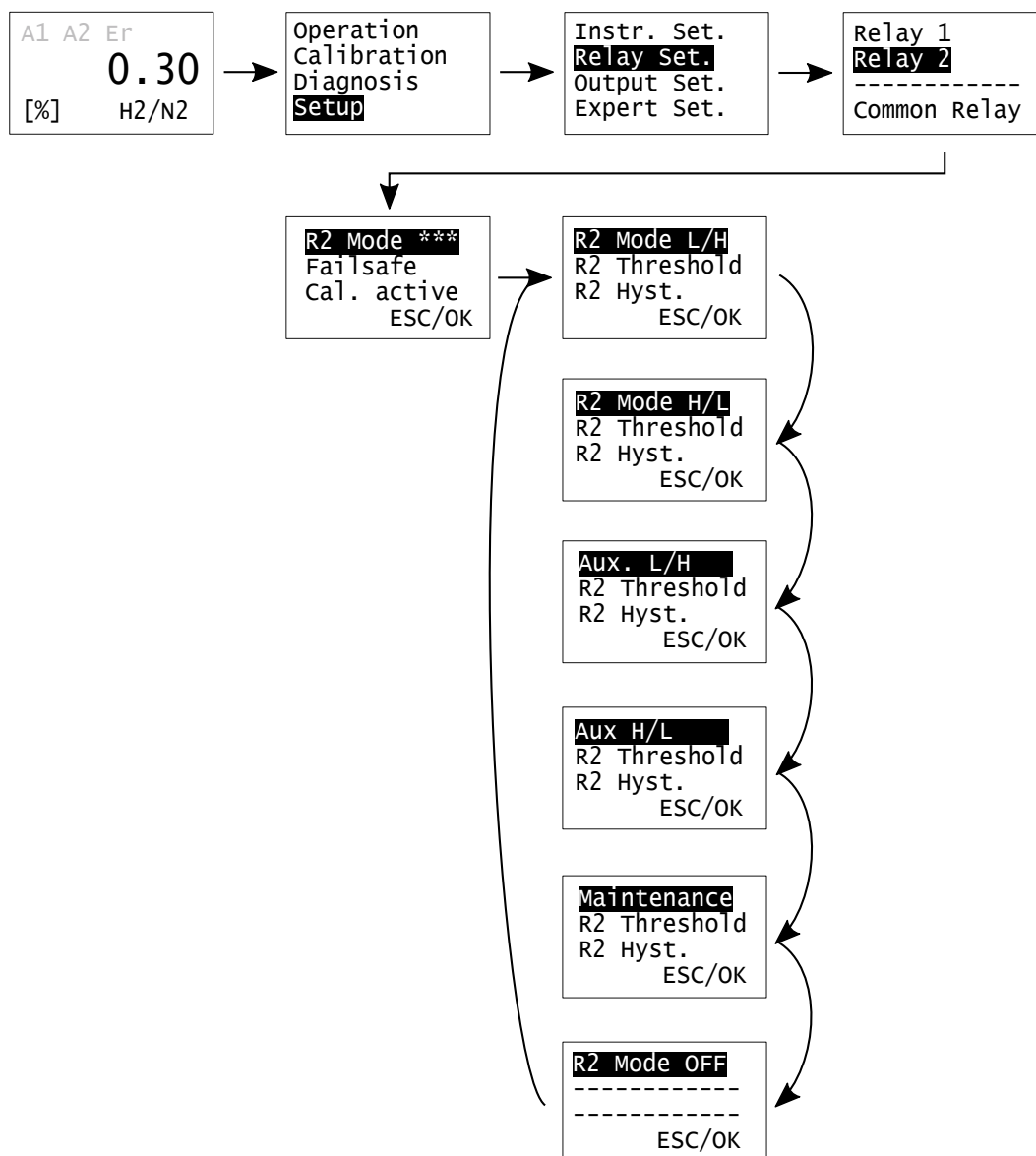

Figure 8.12: Setup of the additional Maintenance mode option of Relay 2

“Relay 2” provides all functionalities of Relay 1, see description above. In addition Relay 2 permits the external signaling of the “Maintenance” alarm or monitoring an external auxiliary signal with the menu “Aux“. The “Maintenance”-Alarm is always indicated by the yellow flashing LED on the front panel. The FTC300 is still functioning but should be put into maintenance in the near future. “Aux H/L” and “Aux L/H” can be used to monitor an external signal that is routed to the analog input of the device. All other settings for relay 2 can be made analogously as for relay (see Sections 8.3.1 to 8.3.5).

8.3.7 Common Relay

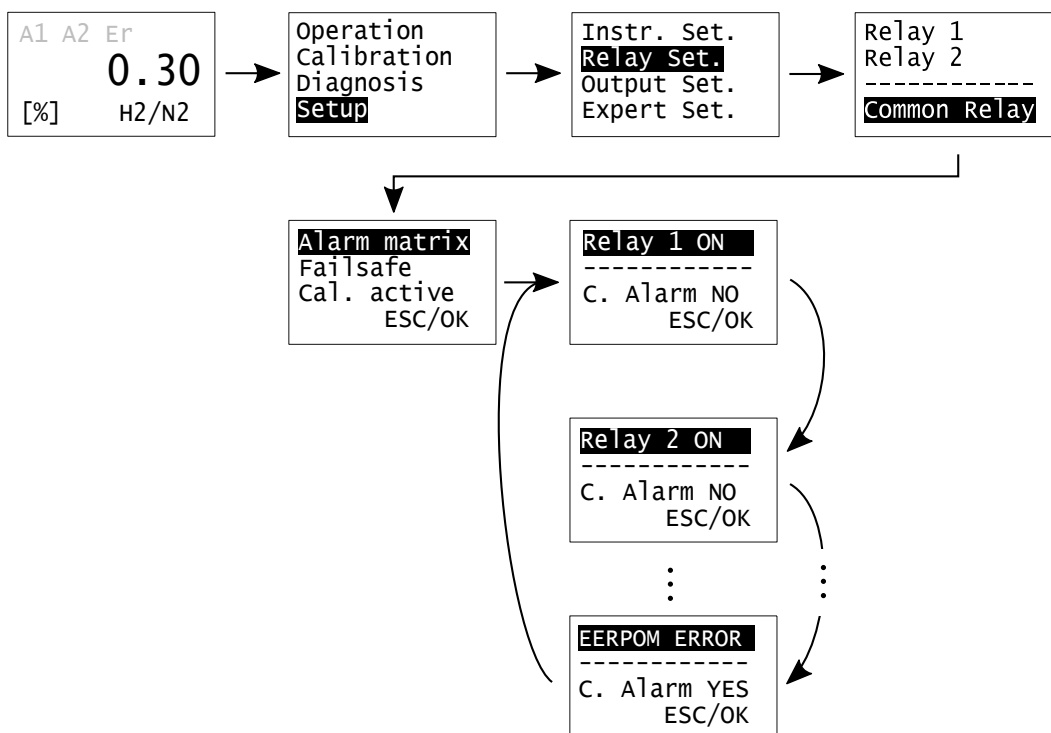
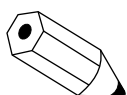

Figure 8.13: custom setup of the Common Relay

In the “Common Relay” menu, relay behaviour based on the following errors can be defined:

- threshold alarms from relay 1 and / or 2
- external error
- internal errors (see Chapter 9 "Appendix: System Errors" for a detailed description)

The menu “Alarm matrix” offers a list of errors that can be included in the common relay. Scroll forward through the list with <ENTER> and backwards with <UP>. The third display line indicates whether this error is included (“C. Alarm YES”) or not included (“C. Alarm NO”) in the common relay. Press <RIGHT> to proceed to the third display line and press <ENTER> to switch between “C. Alarm YES” and “C. Alarm NO”. Confirm with “OK”. If one or more errors included in the Alarm matrix by “C. Alarm YES” are pending, the common relay triggers.



In the default factory settings all internal errors described in Appendix A are included in the common relay.

8.4 Analog Output Setup

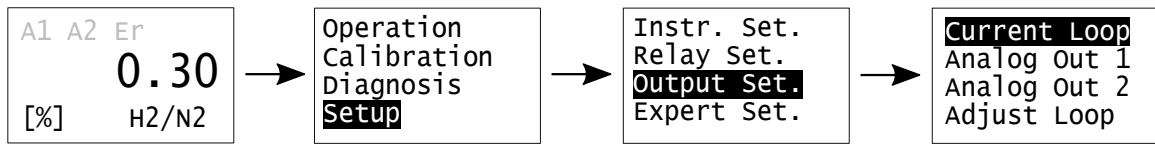

Figure 8.14: Analog output setup menu

The FTC300 is equipped with three analog outputs. “Current Loop” is an isolated current output. “Analog Out 1” and “Analog Out 2” are not DC-isolated outputs with an output range from 0 to 10 V. In the “Output Setup” menu the analog outputs can be configured.

8.4.1 Current Loop modes and adjustment of the measuring range

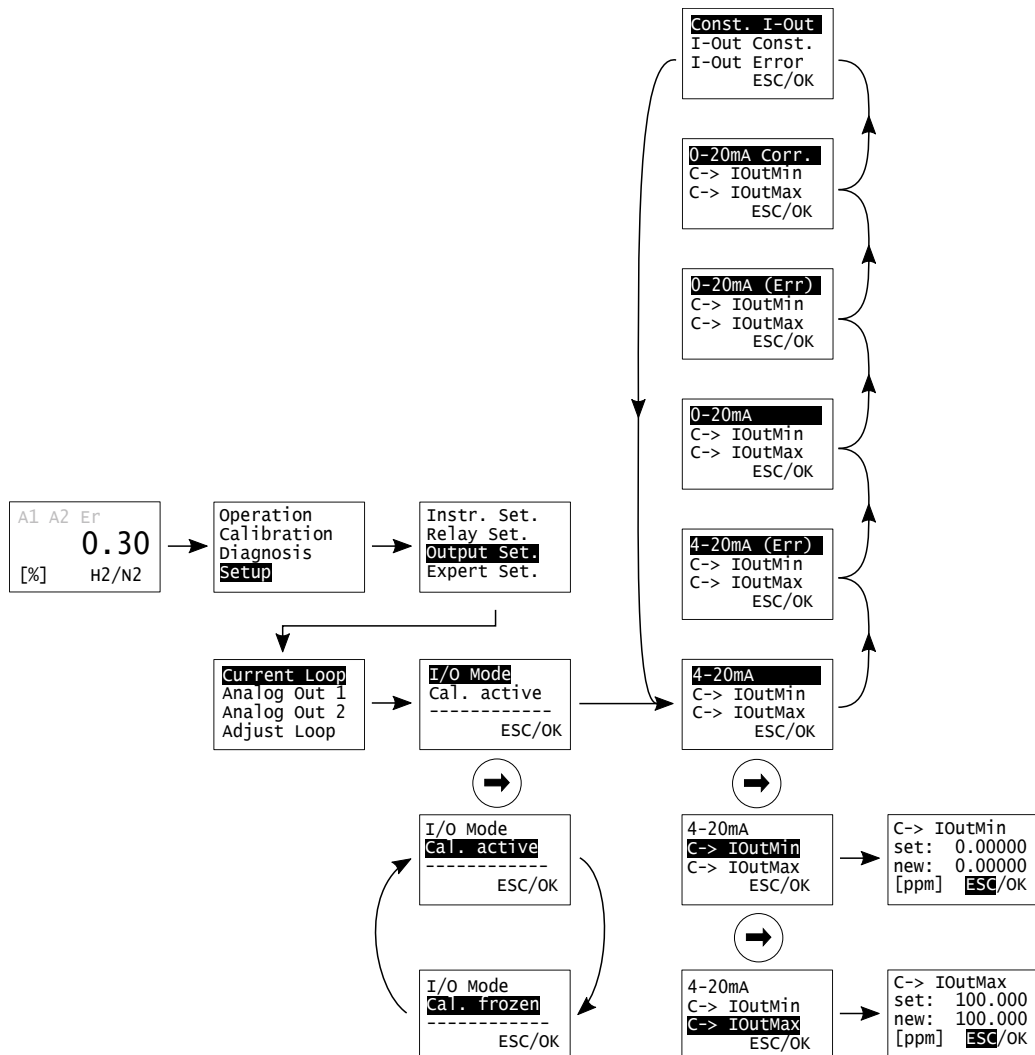

Figure 8.15: Current Loop setup menu

In the “Current Loop” menu the range of the current output and the behavior of the current loop during

calibration and in case of an error are defined. In the I/O-Mode submenu you can toggle through a list of different output modes by pressing <ENTER> when the first line (e.g. 4-20mA) is selected.

Available current loop output modes are:

- "I/O Mode,4-20mA": The loop current ranges from 4mA to 20mA. 4mA correspond to the starting point of the measuring range as defined in "C-> loutMin", 20mA correspond to the end point of the measuring range as defined in "C-> loutMax".
- "I/O Mode, 4-20mA (Err)": This mode works similarly as the previously described mode. In addition, in case of an error the current output is set to a specified value (default value: 3mA). If you wish to change the error current, please change the I/O-mode to "Const. I-Out" and specify a custom error current ("I-Out Error") for your application. Then switch back to "I/O Mode, 4-20mA (Err)".
- "I/O Mode, 0-20mA": The loop current ranges from 0mA to 20mA. 0mA correspond to the starting point of the measuring range as defined in "C-> loutMin", 20mA correspond to the end point of the measuring range as defined in "C-> loutMax".
- "I/O Mode, 0-20mA (Err)": This mode works analogously to "I/O Mode, 4-20mA (Err)" but in a 0-20mA current range. Please note, that the default error current is set to 3 mA, lying inside the typical output value range! The error current can be changed manually (see "I/O Mode, 4-20mA (Err)").
- "I/O Mode, 0-20mA (Corr.)": The current output of this mode creates a voltage drop from 0V to 10V over a 510 Ohm resistor (Correction factor: Parameter 73).
- "Const. I-Out" : The output of the current loop is a constant current specified in the submenu "I-Out Const". Set the value to 0.0mA if the current loop is not used.

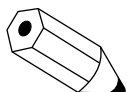

The current specified for signalling errors should be outside the measuring range. By default the error current is set to 3.0mA, values up to 22.0mA can be set.

When choosing the "Cal. active" option, the currently measured concentration value is signalled through the current output during calibration. With the setting "Cal. frozen" the last measured value before calibration is shown at the current output.

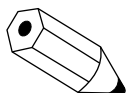

If requested in your order, the current loop output can be changed into a 0 V to 10 V voltage output. With this option the 0 mA to 10 mA mode(s) should be used, then 0mA correspond to 0 V and 20 mA correspond to 10 V.

8.4.2 Analog Output 1

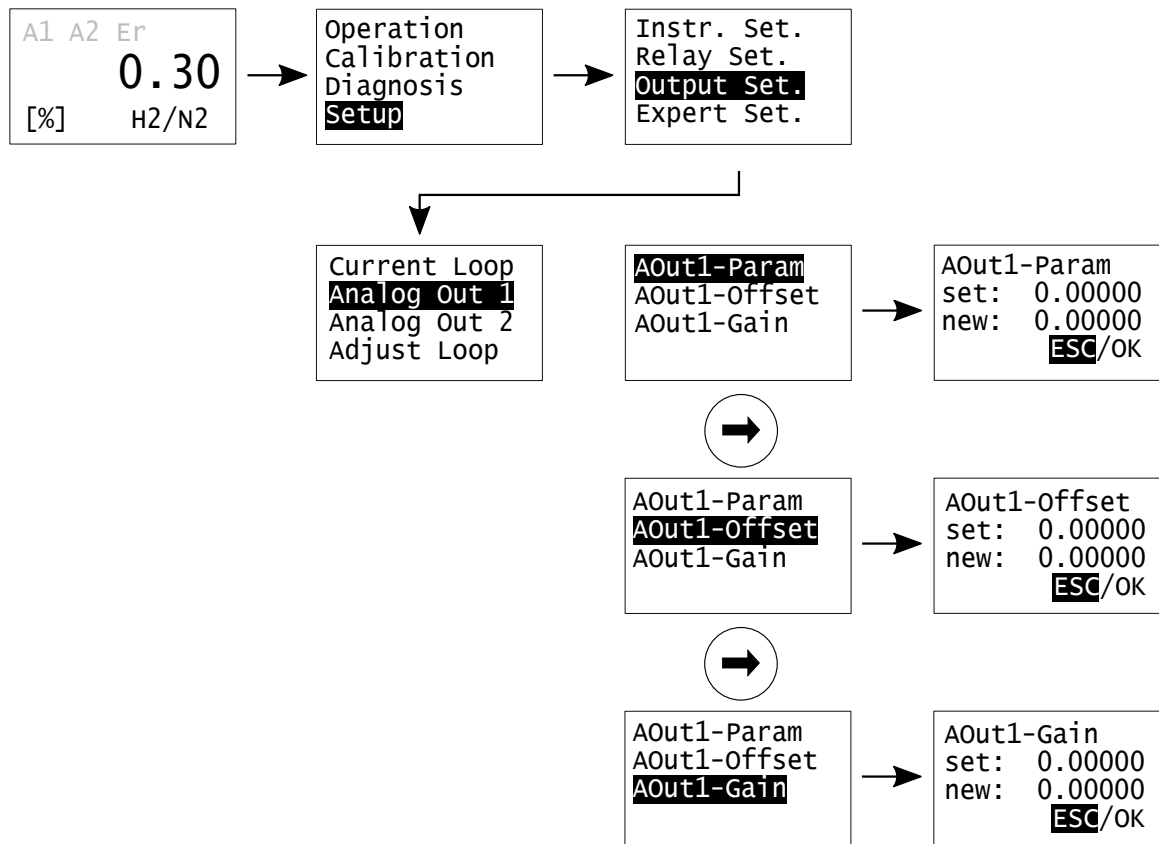

Figure 8.16: Setup of Analog Output 1

“Analog Out 1“ is a non DC-isolated 0 to 10V output. The maximum load is 1kOhm.

Several parameters can be routed to the analog output. In the “AOut-Parameter“-menu you can select the signal you wish to route to the analog output by entering the value number. If you wish to route the linearized measuring signal, select 1.00000. Please contact Messkonzept for a list of paramters available in your device.

“AOut1-Offset“ and “AOut-Gain“ allow scaling of the analog output according to a linear equation:

$$\text{Output} = \text{AOut1Gain} \cdot \text{signal} + \text{AOut1Offset}.$$

8.4.3 Analog Output 2

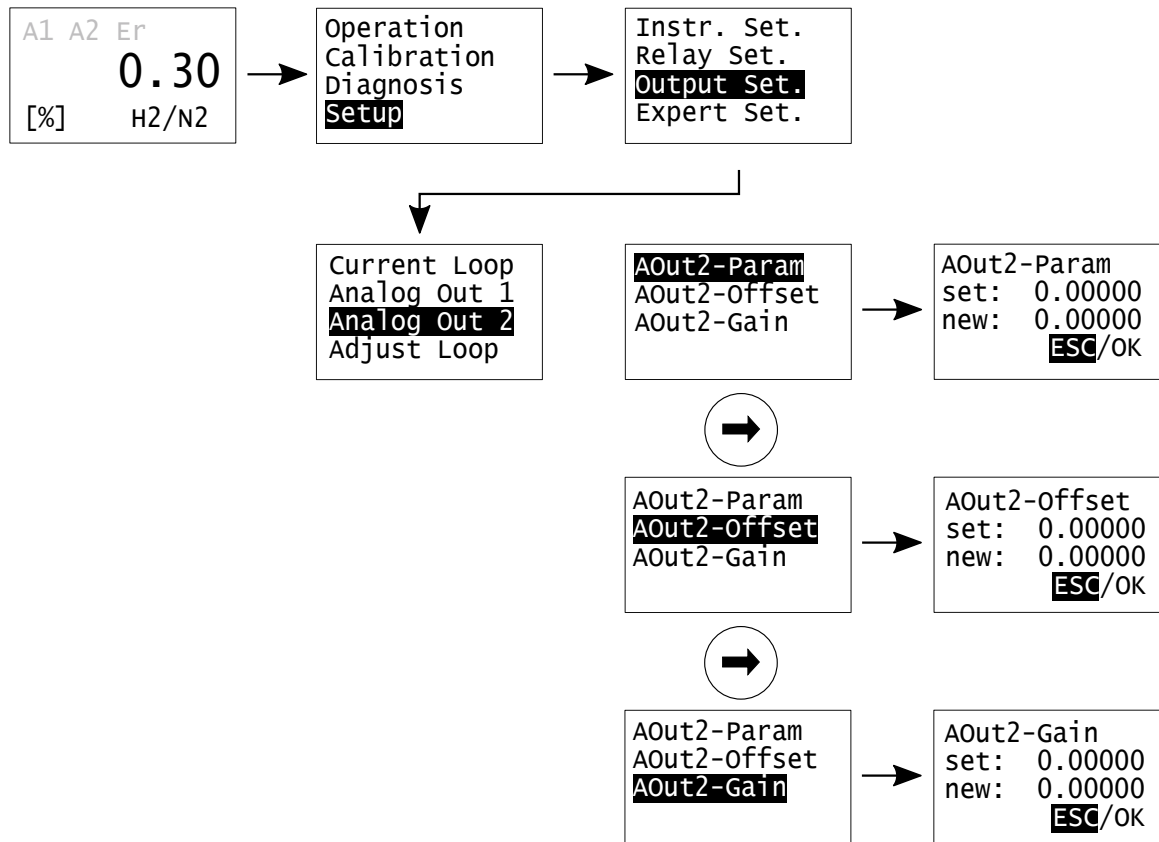

Figure 8.17: Setup of Analog Output 2

All “Analog Out 2” settings can be made analogously as for “Analog Out 1” described before.

8.4.4 Current loop calibration

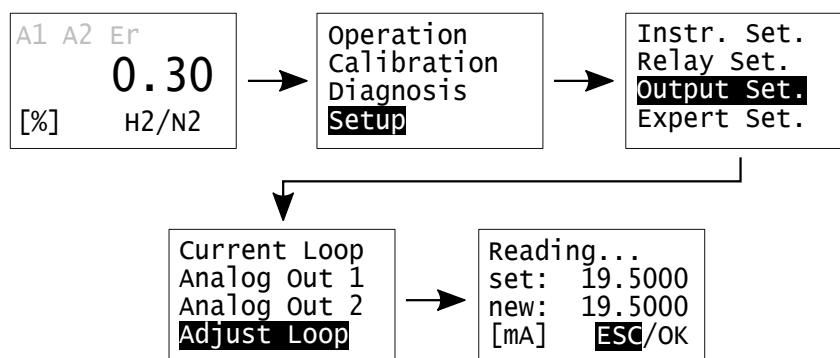

Figure 8.18: Calibration of the current loop

In the menu “Adjust Loop” the current loop can be calibrated. Opening the menu “Adjust Loop” sets the current loop output to 19.500mA. Measure the resulting real current at the output (e.g. with a multimeter) and enter the measured value in the third display line, then confirm with “OK” and <ENTER>. After successful adjustment the multimeter should show a value of 19.5mV.

8.5 Expert Setup

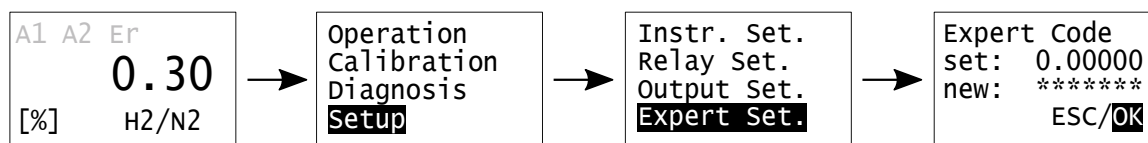

Figure 8.19: Expert Setup menu

The Expert Setup provides a couple of functionalities that should only be used by an advanced user or expert:

- set parameters
- reset to factory settings
- change the “Operator Code“ and the “Expert Code“
- swap between “Normal Mode“ and “Safety Mode“
- simulate alarms and analog outputs



The settings explained here are for advanced users or experts and should not be entered by normal operators. It is in the responsibility of experts to set the parameters properly. The default expert code is “222.000“.

8.5.1 Parameter

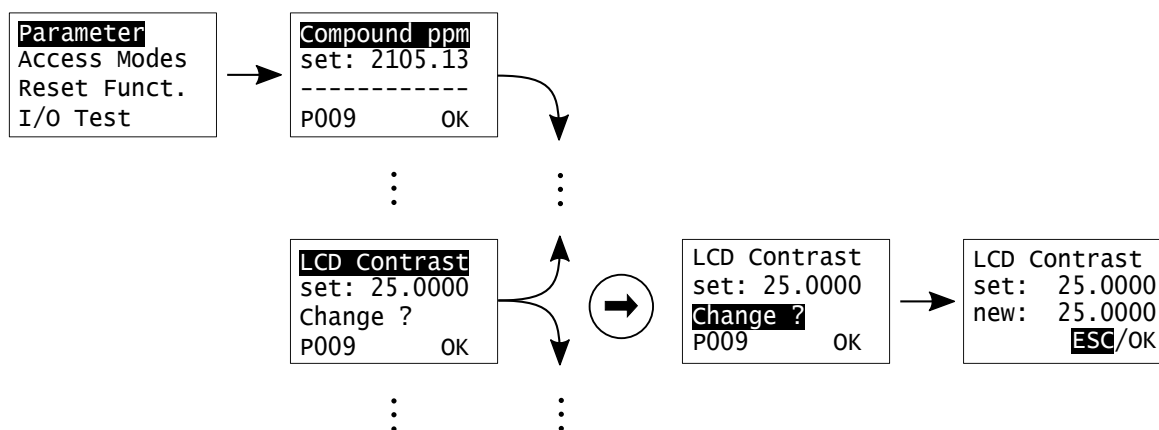

Figure 8.20: Parameter change in expert mode

The configuration of the FTC300 is represented by an internal list of parameters. These parameters govern all settings and functions of the device. In the expert-menu’s parameter list press <ENTER> to scroll forward through the list and backwards by pressing <UP>. Some parameters cannot be changed (e.g. sensor information such as “Compound ppm“, see Figure above) others can be changed (e.g. “LED Contrast“, see Figure above). All changeable parameters are indicated by “Change?“ in the third line of the display. Selecting and clicking “Change?“ opens a submenu in

which a parameter's value can be modified.



Setting certain parameters to improper values can cause faulty measurement results, malfunctions or even permanent physical destruction of the device!

8.5.2 Access Modes

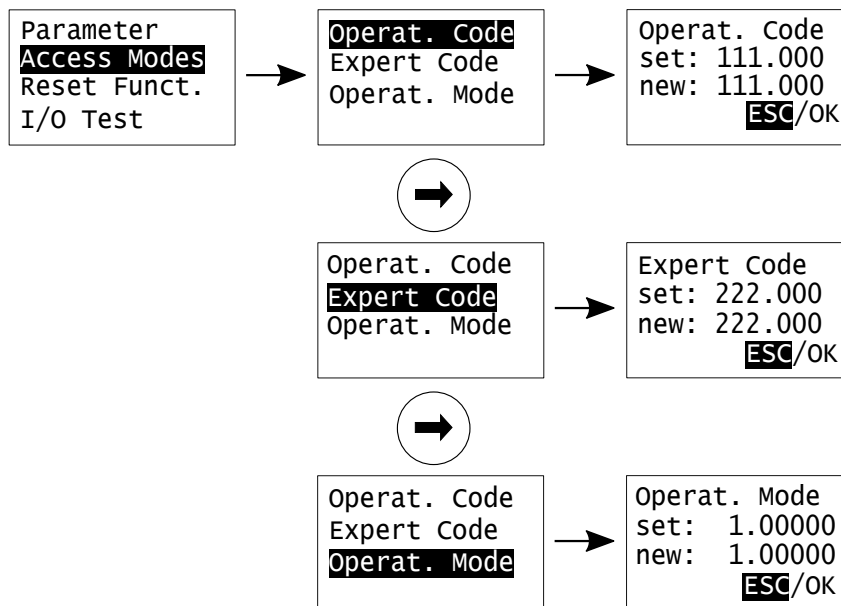

Figure 8.21: Access Mode menu

In this menu the passcodes for the “Operator Mode” and the “Expert Mode” can be changed. Further, the device’s mode can be switched between “Safety Mode” and “Operation Mode”. For the “Operation Mode” set “1.00000” in the menu “Mode Set”, for the safe mode enter “3.00000”. In the safe mode, every change of settings requires manual input of the Operator Code.

8.5.3 Reset Functions

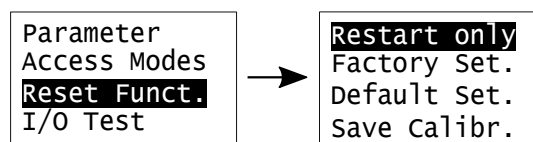
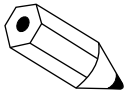

Figure 8.22: Reset Functions menu

This menu provides three reset functions and the possibility to save the current calibration parameters to the Factory Settings:

- “Restart only”: Restart of the software
- “Factory Set.“: Resets all parameters to the factory set values

- “Default Set.“: Resets all parameters to the default set values. CAREFUL: These values are not suited for a properly working device,
- “Save Calibration“: Saves the parameters relevant to calibration. They can be retrieved by “Factory Set.“



If a reset to Factory Settings is performed without saving the calibration parameters beforehand, a new calibration might be necessary.



If the device, against the given warnings, was reset to “Default Settings“ the parameters relevant for the proper operation are overwritten by default values. With these values the device will not work properly. The correct parameters (contact Messkonzept) have to be written to the device again, see Section 8.5.1 or the manual of SetApp which you can find on www.messkonzept.de.

8.5.4 Test of Relays, Analog Outputs and Connections

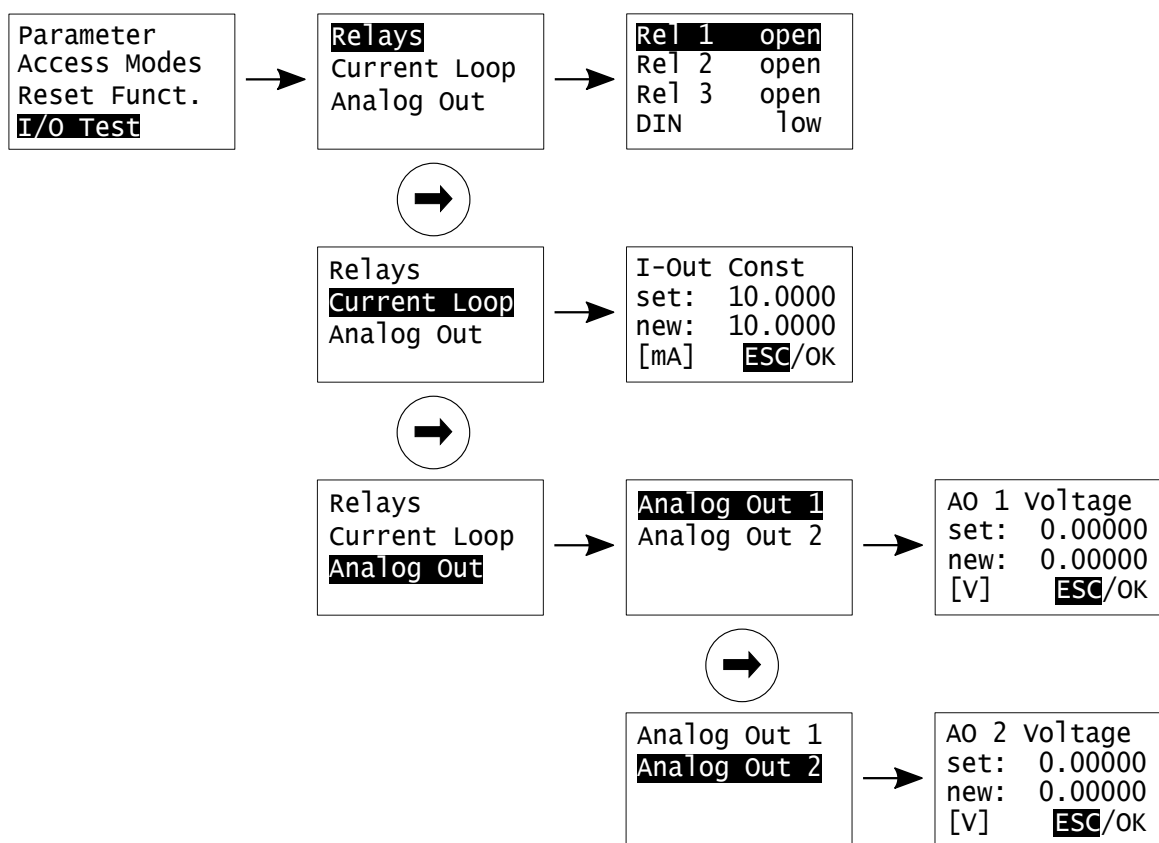

Figure 8.23: I/O Test menu

The “I/O Test“ menu provides the opportunity to set the following properties to a defined status in order to test subsequently connected equipment:

- Relay 1 (Rel 1) (open/closed)

- Relay 2 (Rel 2) (open/closed)
- Common Relay (Rel 3) (open/closed)
- Current of current loop
- Voltage for Analog Out 1
- Voltage for Analog Out 2

The digital input "DIN" is "low" for voltages below 4.6V and "high" above 11.4 V. The output "Current Loop" can be set to currents between 0 and 22mA. The analog outputs 1 and 2 can be set to supply a voltage between 0V and 10V.



Note! All test signals are permanently on until leaving the "I/O Test" menu. It is the responsibility of the expert to assure that the I/O test does not interfere with the subsequent connected systems and processes in an unintended way.

Chapter 9

Appendix: System Errors

In this appendix possible error messages on the FTC300 (see Section 7.2) are listed.

In case of an error please check for the description of the error and the actions recommended to remove possible causes. In case this does not lead to a solution, please contact Messkonzept and describe the circumstances that led to this error. Some issues can be resolved through remote maintenance.

If the error persists you might be requested to send the FTC300 back to Messkonzept. Please pay attention to these points when sending the device:

- Close gas ports to keep gas duct clean. Preferably use black rubber caps that came with delivery.
- Put the device in a suitable shockproof packing material. Preferably use the foam box that came with delivery.
- Please attach a short note with a description of the problem or refer to prior mail correspondence on this subject with Messkonzept.



Never open the housing of the FTC300. Warranty is void if the housing was opened, refrain from attempts of repairing the device yourself! Messkonzept may charge more for the repair if the housing was opened. It is more work to check if an attempted repair by the user lead to further damages.

Displayed label	Cause	Default range	corrective measure
EEPROM ERROR	Error reading or writing data to or from internal FLASH-EEPROM	-	Repeat procedure. If the error persists, send the device to Messkonzept with description of error.
CAL GAIN ER	Calibration gain exceeding max. allowed range	0.5-1.5	Check if the used test gas concentration accords with the set concentration. Repeat procedure. If the error persists, send the device to Messkonzept with description of error.
CAL OFFS ER	Calibration offset exceeding max. allowed range	100 mV	See CAL GAIN ER
CAL DEV ER	Calibration deviation exceeding max. allowed range	50000 ppm	See CAL GAIN ER.
CAL VAR ER	Calibration variation exceeding max. allowed range	1000ppm	Repeat procedure. Check if the measurement is stable before data sampling. Are there sudden fluctuations in relevant process parameters, for example pressure pulses caused by a pump? Has the calibration gas flooded the device properly? Please verify your calibration setup and repeat the calibration. If the error persists, send the device to Messkonzept with description of error.

Displayed label	Cause	Default range	corrective measure
BT MIN ER	Block temperature below specified range	SetTemp-0.6K	The device might still be warming up after start-up or a sudden change of ambient temperature and/or gas flow occurred and disturbed the temperature control loop temporarily. Please wait for a couple of minutes and see if the error persists. Another reason for the error might be operation of the device outside the specified ambient temperature or gas temperature range. Consider the device specifications. If the error persists, send the device to Messkonzept with description of error.
BT MAX ER	Block temperature above specified range	SetTemp+0.6K	<i>See BT MIN ER.</i>
BU MIN ER	Bridge voltage below specified range	1V	Send the device to Messkonzept with description of error.
BU MAX ER	Bridge voltage above specified range	11V	Send the device to Messkonzept with description of error.
TC MIN ER	TC-signal below specified range	500mV	Send the device to Messkonzept with description of error.
TC MAX ER	TC-signal above specified range	7000mV	Send the device to Messkonzept with description of error.
EXT. ERROR	Error routed from input "DIN" (0V=no error, +24V=error)	Signal <14V	Check the surveyed external unit.

Table 9.1: Description of System Errors

Chapter 10

Appendix: Specifications

10.1 Specification of Thermal Conductivity Measurement

Attribute	Range / Precision
Linearity	< 1 % of range
Warm up time	Approx. 20 min; up to 1 h for small measuring ranges
Flow rate	10 l/h - 150 l/h, 60 l/h - 80 l/h (recommended)
T90-time	< 1 sec at flow rate higher 60 l/h (or dependant on user selected T-90-filter time)
Noise	< 0.5 % of smallest range
Drift at zero point	< 2 % of smallest range per week
Repeatability	< 1 % of range
Error due to change of ambient temperature	< 1 % of smallest range per 10 K temperature change
Error due to change of flow at 80 l/h	< 1 % of smallest range per 10 l/h
Error due to change of pressure (800 hPa < p < 1200 hPa)	< 1 % of smallest range per 10 hPa

Table 10.1: Specification of TC measurement

10.2 Electrical Specifications

Unit / Interface	Feature	Value
Display	128 x 64 dot graphic LCD	
Keypad	3 short-travel keys	
Analog Input 1/2	Voltage range:	0 to 10 V
	Reference potential:	ground
	Input resistance	approx. 50 k Ω
	Resolution	24 bit
Current Loop	Signal Current:	0/4 to 20 mA
	Reference potential:	fully floating, max. ± 500 V to ground
	Burden:	max. 800 Ω
	Resolution:	16 bit
Analog Output 1/2	Voltage range:	0 to 10 V
	Reference potential:	ground
	Load resistance:	min. 10 k Ω
	Resolution:	16 bit
Relay 1/2/3	Maximum Voltage:	30 V
	Switching current:	0.5 A (max.)
	Switching capacity:	10 W (max.)
	Reference potential:	fully floating, max. ± 500 V to ground
Power Supply	Voltage range:	24 \pm 6 V DC
	Max. current:	1 A
	Typical current draw:	500 mA
	Safeguard:	PELV (Protective Extra Low Voltage)
Digital Interface	Type:	RS-232
	Baud rate:	19.2 kbaud
	Data:	8 bit
	Parity:	None
	Stop:	1
	Flow control	None
	Reference potential:	ground

Table 10.2: Electrical Specifications

10.3 Permissible Conditions of the sample to be measured

Pressure (absolute)	Standard version: max. 20 bar abs. with flow measurement: max. 2 bar abs. for flammable gases: max. 3 bar abs.
Gas temperature	At 60 l/h: - max. 80 °C at 25 °C ambient temperature - max. 50 °C at 50 °C ambient temperature
Explosivity	non-explosive, except with special protecting devices
Dust, aerosols, oil mist	to be avoided (e.g. via separator/filter)
corrosive gases	only with corrosion-tolerant variant
Humidity or droplets	no falling below dew point in the measuring path, small quantities tolerable with protective filter against condensate and dust

Table 10.3: Environmental conditions

10.4 Environmental conditions

Operating temperature:	-20 °C to 50 °C (-4 °F to 122 °F) or if casing filled with glass balls: -5 °C to 50 °C (23 °F to 122 °F)
Storage temperature:	-25 °C to 70 °C (-15 °F to 160 °F) (not-condensing)
Protection class	IP 65 (if cables are plugged and/or all unused jacks are sealed using protective caps)

Table 10.4: Environmental conditions

10.5 Dimensions

Dimensions:	Depth: 85 mm Width: 144 mm Height: 80 mm without connectors
Weight:	max. 1800 g
Mounting:	Wall mounting

Table 10.5: Dimensions

Chapter 11

Appendix: Menu Tree of the FTC300

In the menu tree, an overview over all menus of the FTC300 firmware is given. Most operations you will do on your device will begin from the operational screen, marked “Start” on the top left corner of the menu tree (see following pages).

You can browse through the menus of the FTC300 using the three buttons on the front panel:

RIGHT / Selection Key

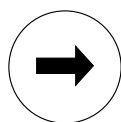

The <RIGHT> key enables the operator to scroll through the various menu items of menus and submenus. The currently selected menu item is marked by black background and is called with the <ENTER> key.

In submenus requiring numerical inputs, the <RIGHT> key scrolls to the next digit and to “ESC/OK” at the end.

UP / Selection Key

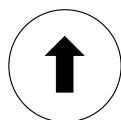

In menus or submenus the <UP> key quits the recent menu and brings you back to the menu above and ultimately to the main menu.

To quit menus with an “ESC/OK” option, select one of these fields with the <RIGHT> key and confirm with <ENTER>.

In submenus requiring numerical inputs, the <UP> key changes the selected digit.

ENTER / Termination Key

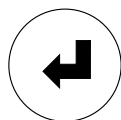

The <ENTER> key calls the item that is marked as selected (selection is indicated through black background highlighted text). Menu items are selected by the <RIGHT> key. In submenus with an “ESC/OK” option the <ENTER> key confirms the selection of “ESC” or “OK”.

This page is intentionally left blank.

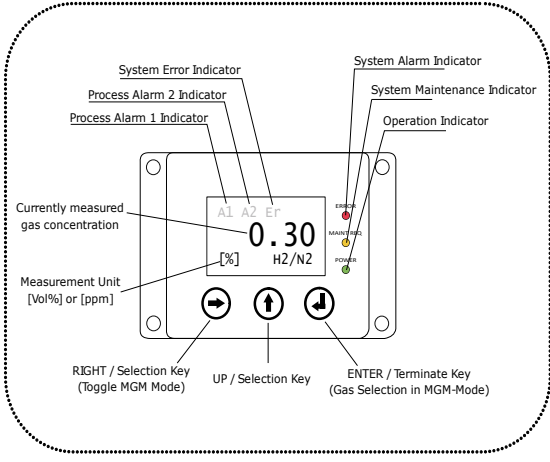
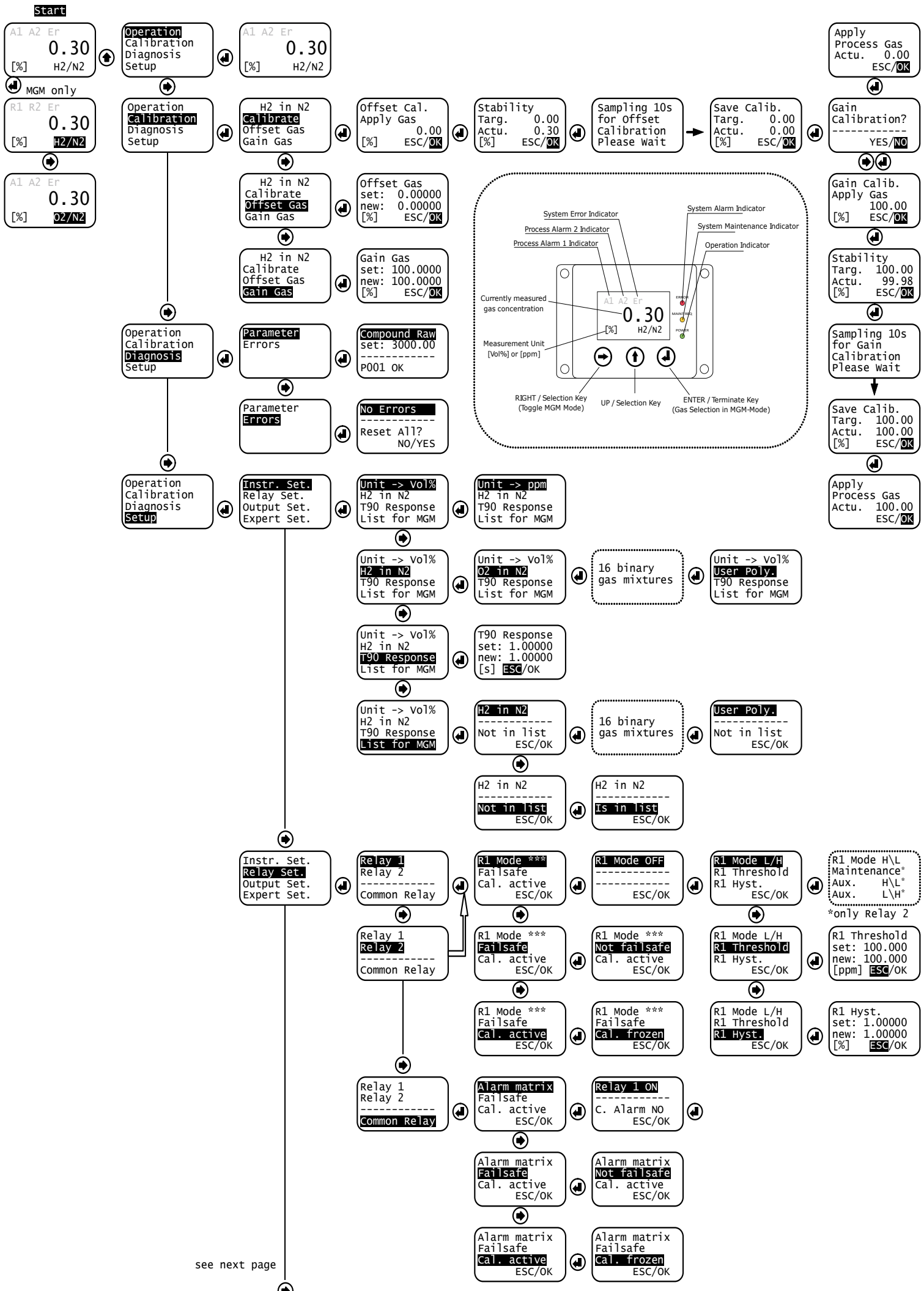

see next page

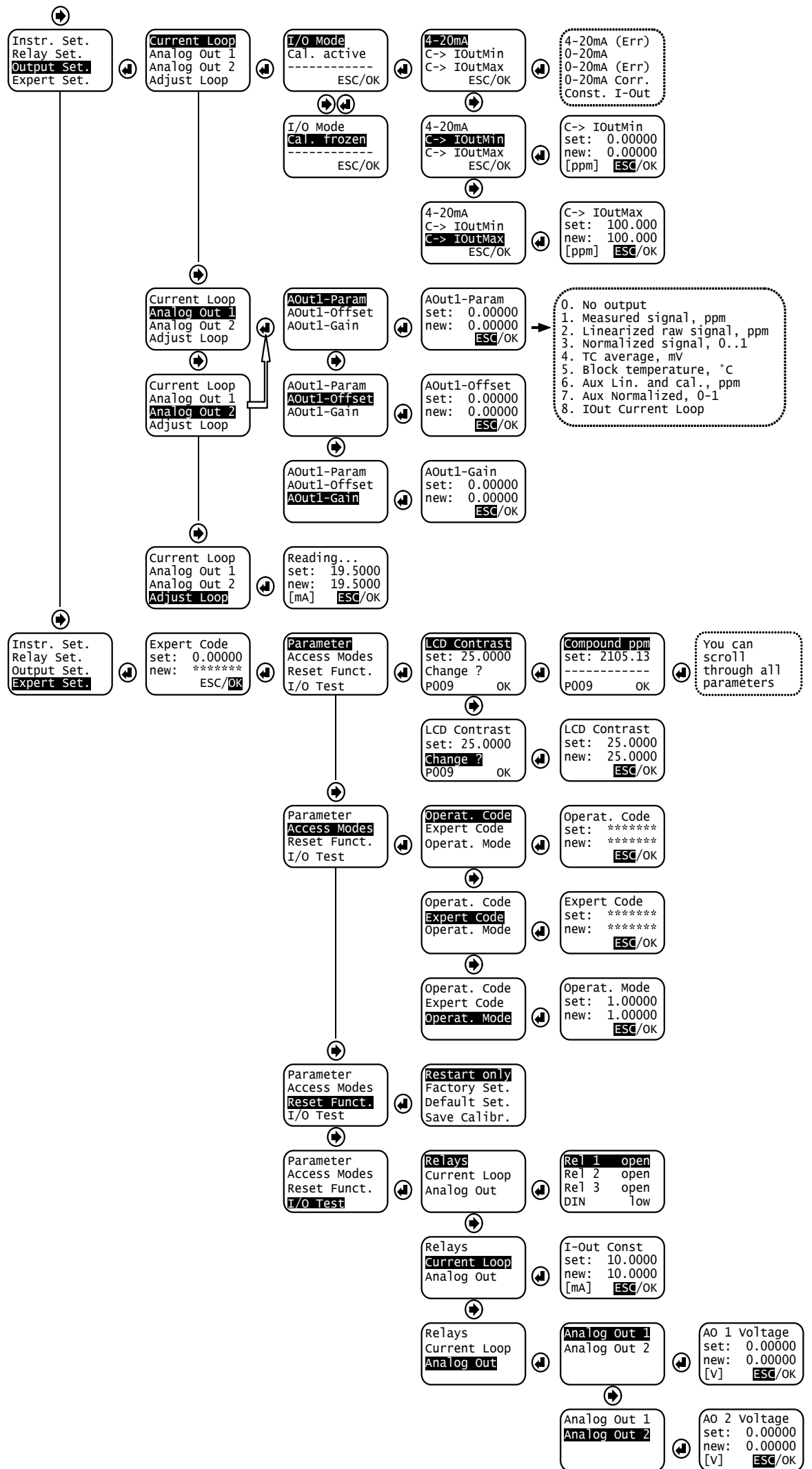

Chapter 12

Appendix: Dimensional Drawing

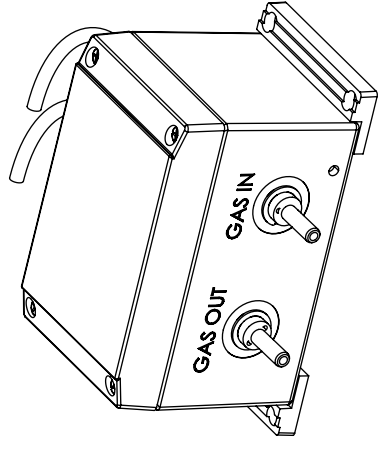

95mm bei fixierten Kabeln /
 122mm bei losen Kabeln
 95mm with cables fixed /
 122mm with cables movable

Steckverbindung / plug-and-socket connection
 A 7 polig / 7 pins
 B 5 polig / 5 pins
 C 8 polig / 8 pins

zulässiger Biegeradius: feste Installation R_{min} 53mm
 bewegliche Kabel R_{min} 80
 tolerable bending radius: fixed installation R_{min} 53mm
 flexibel cable R_{min} 80mm

Obfl.:

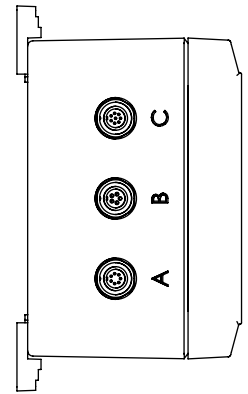
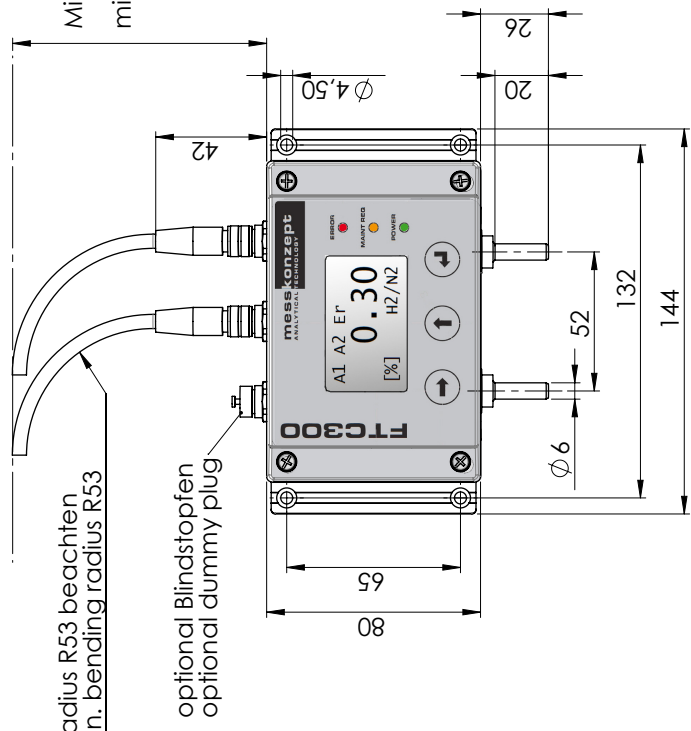
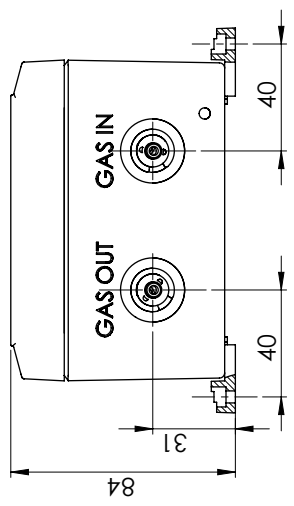

Minimale Freiraum
 minimal clearance

min. Biegeradius R53 beachten
 consider min. bending radius R53

optional Blindstopfen
 optional dummy plug

DIN ISO 2768-mK		Maßstab 1:2	
Datum 28.04.2015		Name Ashmore	
21.11.18 VA		28.04.15 VA	
003		002	
01		01	
Zustf.	Änderungsnr.	Datum	Name
FTC 300		Massbild	
A090-X005		Blatt 1	
		1	
		CAD	

Messkonzept GmbH

Analytical Technology

Niedwiesenstr. 33
60431 Frankfurt
Germany

Telefon +49 69 53056444

Fax +49 69 53056445

info@messkonzept.de

www.messkonzept.de

Managing Director

Dr. Axel-Ulrich Grunewald

Place of jurisdiction Frankfurt HRB 49940

VAT ID: DE211207233